

Order Online at
www.IrvanSmith.com

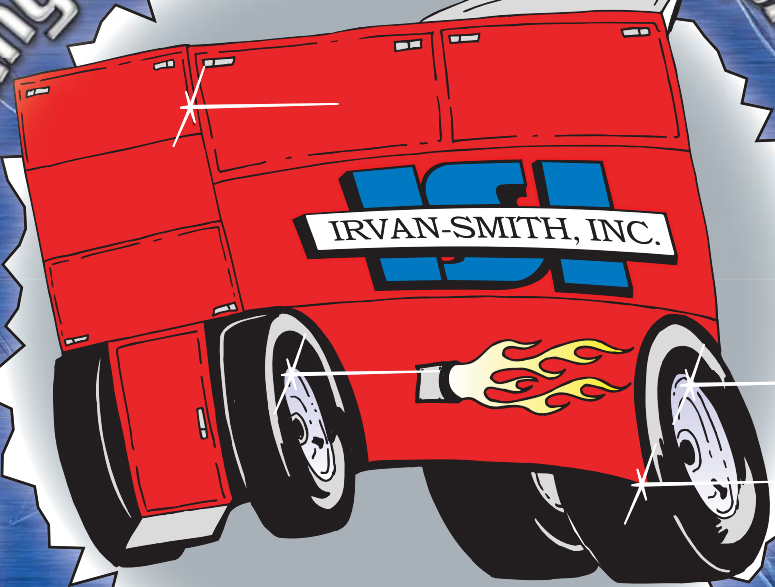

2008
Volume 24

Racing & Fabrication Equipment



704-788-2554
800-221-7223

www.IrvanSmith.com

RIVETS

DOME HEAD RIVETS



Aluminum Rivet with Aluminum Mandrel

(All Quantities Approx.)

All rivets also available in full carton quantities.

3/16 Large Flange

Part No.	Size	Quantity	Price
ABA64L	3/16 x 1/4 Grip	250	\$14.75
		500	\$29.00
		1000	\$52.50
		3000 Ctn.	\$119.00
ABA66L	3/16 x 3/8 Grip	250	\$14.75
		500	\$29.00
		1000	\$52.50
		2500 Ctn.	\$83.50
ABA68L	3/16 x 1/2 Grip	250	\$16.75
		500	\$31.50
		1000	\$57.75
		2000 Ctn.	\$81.50

3/16 Small Flange

Part No.	Size	Quantity	Price
ABA64	3/16 x 1/4 Grip	250	\$9.00
		500	\$16.75
		1000	\$31.50
		5000 Ctn.	\$103.50
ABA66	3/16 x 3/8 Grip	250	\$9.50
		500	\$17.75
		1000	\$33.50
		4500 Ctn.	\$106.50
ABA68	3/16 x 1/2 Grip	250	\$10.50
		500	\$19.00
		1000	\$36.75
		4000 Ctn.	\$107.00

1/8 Large Flange

Part No.	Size	Quantity	Price
ABA44L	1/8 x 1/4 Grip	250	\$9.50
		500	\$15.75
		1000	\$26.25
		8000 Ctn.	\$149.00

1/8 Small Flange

Part No.	Size	Quantity	Price
ABA42	1/8 x 1/8 Grip	1000	\$16.00
		10,000 Ctn.	\$107.50
ABA44	1/8 x 1/4 Grip	1000	\$16.00
		10,000 Ctn.	\$107.50
ABA46	1/8 x 3/8 Grip	250	\$5.25
		10,000 Ctn.	\$126.00
ABA48	1/8 x 1/2 Grip	250	\$6.25
		8000 Ctn.	\$132.25

ALUMINUM BACK-UP WASHERS

Part No.	Size	Quantity	Price
1-8-BU-500	1/8"	500	\$9.00
1-8-BU-1000		1000	\$17.00
1-8-BU-CTN		20,000 Ctn.	\$237.00
3-16-BU-500	3/16"	500	\$11.00
3-16-BU-1000		1000	\$21.00
3-16-BU-CTN		20,000 Ctn.	\$315.00



LARGE SECONDARY HEAD RIVETS

Designed especially for plastics and other brittle materials, this rivet has a secondary head that forms large "folds". This provides a larger bearing surface, resists pull-through or cracking that can occur in some materials with a standard rivet.



Part No.	Size	Quantity	Price
ABAS44	1/8 x 1/4 Grip	250	\$18.50
		500	\$36.50
		1000	\$70.00
		10,000 Ctn.	\$695.00
ABAS46	1/8 x 3/8 Grip	250	\$18.50
		500	\$36.75
		1000	\$69.25
		5000 Ctn.	\$299.25
ABAS64	3/16 x 1/4 Grip	250	\$21.00
		500	\$42.00
		1000	\$82.00
		4000 Ctn.	\$283.50
ABAS66	3/16 x 3/8 Grip	250	\$29.00
		500	\$57.75
		1000	\$105.00
		2500 Ctn.	\$231.00
ABAS66LF	3/16 x 3/8 Grip	250	\$35.00
		500	\$67.50
		1000	\$120.00
		2500 Ctn.	\$240.00
ABAS68	3/16 x 1/2 Grip	250	\$35.00
		500	\$67.50
		1000	\$120.00
		5000 Ctn.	\$575.00

MULTI-GRIP / COUNTERSUNK RIVETS

Aluminum Rivets with Steel Mandrel

Part No.	Dome Head/ Multi-Grip	Quantity	Price
ABS 41-43	1/8x1/32 to 3/16	250	\$10.50
		500	\$21.00
		1000	\$36.75
		10,000 Ctn.	\$273.00
ABS 43-45	1/8x5/32 to 5/16	250	\$10.50
		500	\$21.00
		1000	\$36.75
		10,000 Ctn.	\$273.00

Part No.	Countersunk/ Multi-Grip	Quantity	Price
ABS 41-44C	1/8x1/32 to 1/4	250	\$14.75
		500	\$26.25
		1000	\$50.50
		10,000 Ctn.	\$378.00
Part No. ABS 45C	Countersunk 1/8 x 5/16 Grip	250	\$12.50
		500	\$22.00
		1000	\$42.00
		10,000 Ctn.	\$317.50

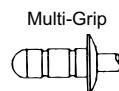

Functions in a wide range of material thicknesses

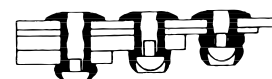

COLORED RIVETS

PAINTED Rivets with Urethane coating

This super tough coating resists scratching, chipping and marring. These coatings match the colored aluminum presently used in the racing market. These are aluminum rivets with steel mandrels.

Part No.	Size	Quantity	Price
ABS66L Color	3/16 x 3/8	250	\$12.50
ABS66L Millfinish	3/16 x 3/8	250	\$10.50

Stock colors: **Black** **Pepsi Blue** **Yellow**
 Heron Blue **Red**
 Orange **White**

Other colors may be special ordered.
 Colored 1/8" rivets also available by special order.

HEAVY DUTY AIR RIVETER



Capacity Aluminum or steel rivets to 3/16"
 Nose Pieces 3/16", 5/32", 1/8", 3/32"
 Weight 3.8 lbs
 Air Pressure 80-100 PSI
 Air Consumption 4.2 CFM
 Air Inlet Thread Size 1/4 PT
 Pulling Head Length 2 5/8"
 Total Height 12"

#001-ARV
\$59.00

Jaw Repair Kit
#002-ARV \$7.50

RIVET DRILL BITS

Made In The USA



*****135° Split Point*****
Sold in Packs of 12 only

#30 For 1/8" Rivets
 O.A.L 1 15/16" (\$.75 ea) **\$9.00 pk.**

#10 For 3/16" Rivets
 O.A.L. 2 1/4" (\$1.00 ea) **\$12.00 pk.**

POP® AIR RIVETER



Designed for high production and trouble-free operation with a variety of applications. Comes with 1/8", 5/32" & 3/16" nose pieces.

#PRG510
\$250.00

18" Whiphose for PRG510
\$10.00

Other POP brand riveters available by special order.

DEBURRING TOOL



With "Rosebud" Bit
#6005-00525
\$25.00

Replacement Bits
#00525 \$8.00

Permits quick deburring operations, accepts 1/4-28 threaded bits. The "rosebud" bit deburrs holes from 1/16" to 3/8". The 6 flute design reduces chattering.

RIVET NUTTER TOOL KIT



#200-TSK
\$85.00

Model #39213 Nut Kit contains the threadsetter tool in a molded plastic case with aluminum threadserts 10 each: 6-32, 8-32, 10-24, 10-32, 1/4-20 & 6 each: 5/16-18 & 3/8-16. Also includes Mandrels, Nosepieces, Wrench & Instructions.

ROUT-A-BURR

Deburring Tool



Use for internal and external deburring depending on blade position. Can rotate clockwise and counter-clockwise. 20 replacement blades included

#307-3332
\$18.00

DEBURRING & COUNTERSINK SET

Set of 5 82° Deburring and Countersink tools:
 1/16", 5/32", 3/16", 5/16", 9/16"

#820-082
\$25.00 set



CLECO FASTENERS

If you have never used Cleco Fasteners you don't know what you've been missing. Clecos are spring-loaded fasteners with a strong, durable steel plated body. Clecos temporarily hold the material in place until it is ready to be fastened permanently. Many car builders hang complete bodies with Clecos before they even use the first rivet.



Can be purchased individually or in kits.

CLECOS

1/8" **\$.45 ea.**

CLECO KITS

1/8" Kit = 40 Clecos + 1 tool - **\$25.00**

3/16" **\$.50 ea.**

3/16" kit = 36 Clecos + 1 tool - **\$25.00**

CLECO TOOL

#0-131
\$7.00

(fits all Cleco fasteners)

Also Available:
3/32", 5/32", 1/4" Clecos
1/8" & 3/16" Clecos in longer grip range

WING NUT FASTENERS

These wing nut "Clecos" hold the two pieces of material together much more firmly than the spring loaded Clecos. Perfect for hanging fiberglass bodies. They draw your material up TIGHT.



Part #	Description	Price
01-8W	0" to 1/2" Grip Range, 1/8"	\$2.75 ea.
01-8WL	0" to 1" Grip Range, 1/8"	\$3.25 ea.
03-16W	0" to 1/2" Grip Range, 3/16"	\$2.75 ea.
03-16WL	0" to 1" Grip Range, 3/16"	\$3.25 ea.
1-4W	0" to 1/2" Grip Range, 1/4"	\$4.00 ea.
1-4WL	0" to 1" Grip Range, 1/4"	\$4.50 ea.

SIDE GRIP FASTENERS

Spring loaded grip used like a "C" Clamp where no holes are provided (i.e., on bonded, glued or laminated sheets)

Actuated with the same tool as Cleco 0" to 3/4" capacity with 1" reach

#CSG-3-4X1
\$2.25 ea.
(Cleco Tool #0-131 \$7.00)



1/4 TURN CAM FASTENERS

4002 Series CAD Plated/Slotted Head Studs



Part #
4002-4
4002-5
4002-6
4002-7
4002-8
4002-9
4002-10

Call for Current Prices

RECEPTACLES

Part #
214-16 Rigid
244-16 Floating

Call for Current Prices



Floating

Rigid

GROMMETS

Part #
4002-N Snap Ring Type
4002-O Snap Ring Type
R-4G Snap Ring
40G16-040 Crimp Type
40G16-070 Crimp Type
40G16-100 Crimp Type
40G16-190 Crimp Type

Call for Current Prices

Grommet Crimp Tool
#BPC-208-T
\$12.50

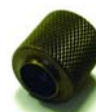

Snap Ring Grommet

Crimp Grommet



Snap Ring

CAM FASTENER PLIERS

For inserting and removing the cam fastener from the grommet



4P3
\$45.00

DRILL FIXTURE

For 1/4 Turn Fasteners Hole separations of .750" and 1.0" for small and large fasteners.

#JG-TOOL
\$60.00



PANEL FASTENERS



OVAL HEAD BUTTONS (Steel)

6400B 7/16" dia.	\$.93 ea.
6450B 7/16" dia.	\$.93 ea.
6500B 7/16" dia. *	\$.93 ea.
6550B 7/16" dia.	\$.93 ea.
6600B 7/16" dia. *	\$.96 ea.



OVAL HEAD BUTTONS (Aluminum)

6450A 7/16" dia.	\$1.03 ea.
6500A 7/16" dia.	\$1.08 ea.
6600A 7/16" dia.	\$1.08 ea.



WINGED OVAL HEAD BUTTONS (Steel)

6450WB 7/16" dia.	\$1.40 ea.
6500WB 7/16" dia.	\$1.40 ea.
6550WB 7/16" dia.	\$1.35 ea.
6600WB 7/16" dia.	\$1.45 ea.



FLUSH HEAD BUTTON (Steel)

6500FB 7/16" dia.	\$.93 ea.
6600FB 7/16" dia.	\$.98 ea.



SELF EJECTING (Flush, Steel)

5400E 5/16" dia.	\$1.84 ea.
5500E 5/16" dia.	\$1.87 ea.
5550E 5/16" dia.	\$1.87 ea.
6500E 7/16" dia.	\$1.91 ea.
6550E 7/16" dia.	\$1.94 ea.



WINGED SELF EJECTING (Steel)

5500EW 5/16" dia.	\$2.26 ea.
5550EW 5/16" dia.	\$2.26 ea.

SPRINGS

5275SP-1"	\$.50 ea.
5325SP-1"	\$.50 ea.
6275SP-1 3/8"	\$.50 ea.
6375SP-1 3/8" *	\$.50 ea.
6425SP-1 3/8"	\$.50 ea.

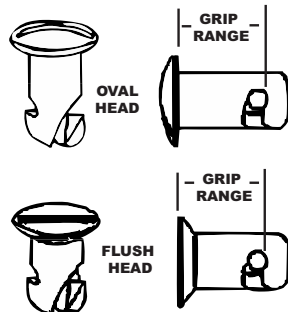
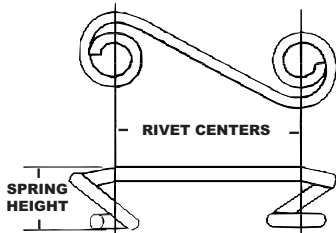
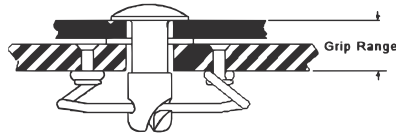
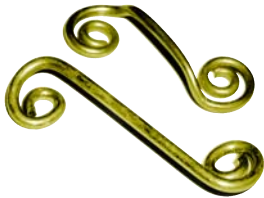

* Most popular size: 500:600 buttons and 6375SP springs

PANEL FASTENER PLATES



A - Flat
1" - \$.40 ea.



B - Beveled
1 3/8" - \$.40 ea.



C - Flat
1 3/8" - \$.40 ea.



D - Beveled Lightweight
1 3/8" - \$.40 ea.

PANEL FASTENER GRIP RANGE GUIDE

Button Length	Spring Number				
	5275SP	5325SP	6275SP	6375SP	6425SP
_400	.149-.184	.099-.134	.156-.199	.056-.099	.006-.049
_450	.199-.234	.149-.184	.206-.249	.106-.149	.056-.099
_500	.249-.284	.199-.234	.256-.299	.156-.199	.106-.149
_550	.299-.332	.249-.282	.306-.349	.206-.249	.156-.199
_600	.349-.384	.299-.334	.356-.399	.256-.299	.206-.249
_650	.399-.432	.349-.382	.406-.449	.306-.349	.256-.299

General Tips

- If you have buttons already, then keep the same button length and change your springs for different thicknesses because they are less expensive to change.
- If you are buying for the first time, try to buy the _500 length buttons because they are in the middle of the sizes and you can use the springs to get different grip ranges.
- The button length column only has _400, _450, _500, etc., because the last three digits of the part number indicate the length of the button. The first number, either a 5 or 6, determines the diameter of the button. So you can use this table for buttons of any diameter by focusing only on the length
- If you use a plate to attach your spring, you must add .100" to your material thickness before determining your spring length.
- If your button and spring combination is just a tad too short or long, you can "tweak" the spring a little by bending it up or down to tighten or loosen the grip.

Use the table to determine the spring and button you need for a particular job.

Step 1: Determine the total thickness of the material the button will go through.

Step 2: If you have a button, find its length in the left column of the chart. If you don't have a button or a preference, use the _500 length button, and look under the spring column until you find your needed thickness.

Example: The total material measures .175" thick and the button length is _500. In the button length column find _500. Then go to the right until you find a range where .175" would be included, which is .156-.199. By looking at the very top of that particular column for a _500 length button going through material thickness .175", you would need to order a 6375SP spring.

Rod End Male		Rod End Female		Ball Bore	Thread SAE	Radial Static Load Capacity lbs.	Price
R.H.	L.H.	R.H.	L.H.				
CM-3	CB-3	CW-3	CG-3	3/16	10-32	1,170	\$ 4.25
CM-4	CB-4	CW-4	CG-4	1/4	1/4-28	2,157	\$ 4.75
VCM-5	VCB-5	VCW-5	VCG-5	5/16	5/16-24	2,750	\$ 5.25
VCM-6	VCB-6	VCW-6	VCG-6	3/8	3/8-24	3,308	\$ 6.25
VCM-7	VCB-7	VCW-7	VCG-7	7/16	7/16-20	4,454	\$ 7.75
VCM-8	VCB-8	VCW-8	VCG-8	1/2	1/2-20	7,409	\$ 9.25
VCM-10	VCB-10	VCW-10	VCG-10	5/8	5/8-18	8,424	\$ 12.75
VCM-12	VCB-12	VCW-12	VCG-12	3/4	3/4-16	12,448	\$ 16.00
CM-3S	CB-3S	CW-3S	CG-3S		10-32		\$ 4.75
CM-4S	CB-4S	CW-4S	CG-4S		1/4-28		\$ 5.75
CM-5S	CB-5S	CW-5S	CG-5S		5/16-24		\$ 6.50
CM-6S	CB-6S	CW-6S	CG-6S		3/8-24		\$ 7.25
MM-4	MB-4	MW-4	MG-4	1/4	1/4-28	2,158	\$ 7.00
MM-5	MB-5	MW-5	MG-5	5/16	5/16-24	2,784	\$ 8.00
MM-6Y	MB-6Y	MW-6	MG-6	3/8	3/8-24	3,915	\$ 9.50
MM-7Y	MB-7Y	MW-7	MG-7	7/16	7/16-20	4,218	\$ 10.50
MM-8Y	MB-8Y	MW-8	MG-8	1/2	1/2-20	6,660	\$ 12.75
MM-10Y	MB-10Y			5/8	5/8-18	7,364	\$ 18.25
MM-12Y	MB-12Y			3/4	3/4-16	11,518	\$ 22.50
XM-4	XB-4			1/4	5/16-24	3,467	\$ 11.00
XM-5	XB-5			5/16	3/8-24	5,323	\$ 12.75
XM-6	XB-6			3/8	7/16-20	7,180	\$ 15.50
XM-7	XB-7			7/16	1/2-20	9,620	\$ 18.25
XM-8T	XB-8T			1/2	5/8-18	12,807	\$ 23.00
XM-10T	XB-10T			5/8	3/4-16	16,565	\$ 30.00
AIRCRAFT TYPE							
AM-8T	AB-8T	AW-8T	AG-8T	1/2	1/2-20	16,238	\$ 30.00
AM-10T	AB-10T			5/8	5/8-18	17,955	\$ 40.00
AM-12T	AB-12T			3/4	3/4-16	28,081	\$ 52.50

JAM NUTS



Size	Right Hand	Left Hand
1/4	\$ 0.20	\$ 0.45
5/16	\$ 0.20	\$ 0.45
3/8	\$ 0.25	\$ 0.50
7/16	\$ 0.35	\$ 0.60
1/2	\$ 0.50	\$ 0.60
5/8	\$ 0.60	\$ 0.85
3/4	\$ 0.75	\$ 1.00

ROD END TAPS

Size	Right Hand	Left Hand
1/4-28		\$ 5.00
5/16-24		\$ 5.50
3/8-24		\$ 8.00
7/16-20		\$ 10.00
1/2-20		\$ 11.50
5/8-18	\$ 12.50	\$ 20.00
3/4-16	\$ 17.00	\$ 25.00



**STEERING SHAFT
SUPPORT ROD END**

Made .007" oversized especially for 3/4" steering shaft

No need to grind out standard rod end or sand down shaft

Threaded 3/4-16 R.H



#CM12-12 - \$18.00

JACK BOLT TAP AND DIE

1 1/8"-12

These hard to find taps and dies are used for chasing threads on jack bolts and jack bolt sleeves used on most stock cars.

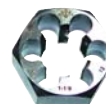

Tap \$35.00 ea.
Die \$40.00 ea.

ISI BEAD ROLLERS AND ACCESSORIES

24" ELECTRIC BEAD ROLLER

The electric motor takes the work out of improving both strength and appearance of panels made of aluminum, steel and other materials.

The foot control allows both hands to guide the material, therefore it is a one man operation.

The electric motor is reversible and has a variable speed feature.

- Throat depth available in 24 inch
- Width of throat accepts up to a 1 1/4" bend
- 1 1/4" radius for efficient design
- 1/4" bead in 16 ga. aluminum or 20 ga steel
- Mounts in bench vise or an optional adjustable stand which can be purchased
- 20' power cord
- 10' control cord
- 1/4" round bead mandrels included



As Seen On DREAM CAR GARAGE

#10-EBR-24
\$550.00

Replacement Motor
#BRG-2Z797
\$150.00

(Stand & Mandrel rack sold separately)

BEAD ROLLER STAND

Shown above for electric model only
Adjustable Height
(Welding assembly required for UPS orders)

#30-EBR-STAND
\$65.00

24" MANUAL BEAD ROLLER

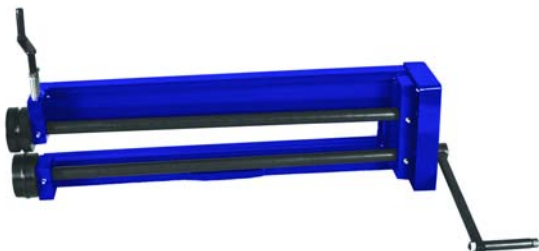

The manual bead roller has a depth of 24". Mounts in bench vise.

- 1 1/4" radius for efficient design
- 1/4" bead in 20 gauge steel or 16 gauge aluminum
- Width of throat accepts up to 1 1/4" bend
- Includes 1/4" round bead mandrels
- Can be converted to electric with changeover kit

#20-MBR-24 **\$335.00**

ELECTRIC CHANGEOVER KIT

Kit includes: Motor, wiring, guard, foot pedal, other necessary hardware and instructions.

#40-ELEC-KIT
\$275.00



HEM ROLL MANDREL SET

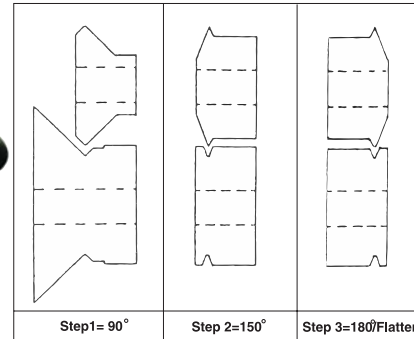

- Dress up sharp edges (wheel well openings)
- Work on curved or straight edges
- Capacity: .040 Aluminum, 20 ga. Steel
- Does not mar prepainted aluminum
- Turns approx. 1/4" hem
- Put the professional touch to your work.

#HEM-#1
\$130.00 set
(4 pc. set)

MANDRELS



3/8" Flat Bead



1/4" Round Bead



Step Roll

All Mandrels fit 7/8" shafts on 3" centers

- 1/8" Round Bead \$55.00 set
- 1/4" Round Bead \$55.00 set
- 1/4" Round Nylon Bead* . . \$75.00 set
- .050 Step Mandrels \$45.00 set
- .080 Step Mandrels \$45.00 set
- .110 Step Mandrels \$45.00 set
- .250 Step Mandrels \$80.00 set
- 1/4" Flat Bead. \$55.00 set
- 3/8" Flat Bead. \$55.00 set
- 1/2" Flat Bead. \$55.00 set
- 1/2" Diamond Bead \$55.00 set
- Blank Mandrel \$30.00 set
- 3" OD x 3" OD
- Blank Mandrel \$30.00 set
- 3" OD x 3 1/4" OD
- Pipe Bead Mandrels. \$95.00 set
- (For Grooving pipe to keep water hose from slipping off. 1 1/2" or larger pipe)
- Gears \$50.00 set

MANDREL RACK



Holds up to 10 sets of mandrels. Bolts onto the electric bead roller stand
#30-EBR-RACK \$60.00

* Special Order Only

"E-Z" EDGER

Turns a 7/32" flange on wheel well openings and other straight or curved edges. No gauge to set. Hand clamps to any bench.

Capacity - 20 gauge and lighter material. Turns a 7/32" flange on a radius as small as 1 3/4" Shipping Weight - 28 lbs.

#EZ-1
\$690.00





TUBING BENDERS

AIR OVER HYDRAULIC



Bends 3/4" thru 1 3/4" O.D. Tubing (Not for EMT)

This specially designed bender makes accurate, smooth bends without kinking, wrinkling or crushing. One forward stroke of the ram makes a full 90° bend (bending action work-hardens the tubing for even greater strength at the bend).

Unit will make bends in steel tubing up to .125 wall and chromoly (4130) up to .058 wall.

Air operated...develops up to 10,000 psi and has a hydraulic overload valve. Operates at 50 to 120 psi to provide instant controlled action and keeps pressure until released.

Complete units in stock...Fully portable.

Manufactured by Irvan-Smith, Inc. and Made in USA

SHOE SETS

Complete set Includes: Shoe, Follow Bar, and Saddle

Tubing O.D. Size	Shoe Radius	Price
3/4"	3-27/64"	\$200.00
7/8"	3-27/64"	\$210.00
1"	4-5/16"	\$210.00
1-1/8"	4-5/16"	\$225.00
1-1/4"	5-5/8"	\$250.00
1-3/8"	5-5/8"	\$325.00
1-1/2"	7-3/16"	\$340.00
1-5/8"	7-3/16"	\$360.00
1-3/4"	8-1/32"	\$370.00
1-7/8"	8-1/32"	\$400.00
2"	8-1/32"	\$420.00

#IS2-01-TB
\$1295.00
 Tubing Bender with pump and one shoe set (your choice of size up to 1 3/4")

(Individual shoes, follow bars or saddles also sold separately)

BUDGET BENDER

Manual Hydraulic Tubing Bender



Features:

- Portable & Affordable
- Bender frame made of welded steel
- Die shoe made of solid cast aluminum
- Pre-Assembled in a self contained package that weighs less than 50 lbs
- 8-ton jack does the bending for you

#IS2-MANUAL-BEND
\$509.00

Includes bender and 1 shoe size

6 die shoe sizes available

- 1 3/4" - 7" radius
- 1 5/8" - 7" radius
- 1 1/2" - 7" radius
- 1 3/8" - 5" radius
- 1 1/4" - 5" radius
- 1" - 5" radius

Additional shoe sets \$244.00 ea.

Williams LOWBUCK® TOOLS

3/4" TUBE BENDER

For SQUARE OR ROUND Tubing

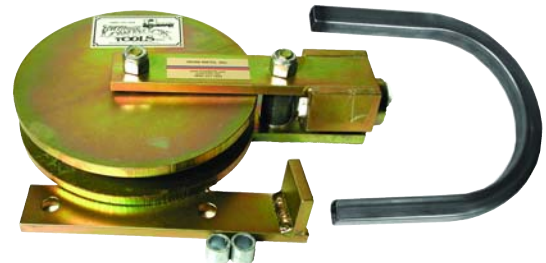

The Lowbuck Tube Bender will bend 3/4" or smaller SQUARE or ROUND tubing in a 3 inch radius, a complete 180° in a matter of seconds. It will bend mild steel, 4130 chromoly, stainless or aluminum. This machine is cad plated...just bolt it to your workbench and go for it!

#LTB-0750
\$155.00

HYBEND

Production Quality Hydraulic Bender

If you have been looking for a production hydraulic bender, this is it. It is a HIGH quality bender for the serious professional. Completely hand fabricated from solid plate and tubular steel. Capable of bending round or square tubing, and solid round, square, flat and 1/2" bar stock.

The bender is self contained 110V AC, 1-1/2 H.P. 4 ton hydraulic - all built on a caster mounted base with a storage shelf for accessories. Bending capacity is from 1/2" OD x 2" radius to 2" O.D. x 6" radius with optional (Hossfeld) die sets . Bends to 180°. Bender base and fame work are unpainted steel. Dimensions are 38" high x 34" long x 24" wide. Shipping weight: 350 lbs.

Base Bender (with NO dies) **\$3050.00**

Tubing Die Sets (3-piece) - Call for Current Prices - Allow 2-3 weeks delivery

1/2" x 2" R049 min wall	3/8" x 5" R065 min wall
3/4" x 2" R049 min wall	1-1/2" x 5" R083 min wall
7/8" x 3" R049 min wall	1-5/8" x 6" R083 min wall
1" x 3" R049 min wall	1-3/4" x 6" R083 min wall
1-1/8" x 3" R065 min wall	1-7/8" x 6" R095 min wall
1-1/4" x 4-1/2" R065 min wall	2" x 6" R125 min wall

Other sizes and radii available



Comes unpainted

Tube Shark[®]



Bender in working position



Bender folded for portability



SharkPool Combo Bender

**Bender with
Pneumatic Pump
Power Unit
\$3400.00**

#TSA-2-1-0002
(Die sets not included)

**Bender with
Commercial
Electric/Hydraulic
Power Unit
\$4953.00**

#TSA-2-1-0003
(Die sets not included)

**SharkPool
Combines TubeShark
Bender & Notcher on
Rolling Bench
\$6800.00**

#TSA-2-1-0006
(Die sets not included)

Round Tubing Bending Die/Shoe Sets (Complete 3 Piece Set)

TSTA-2-1-0003 2" OD on 8"R \$573.00
TSTA-2-1-0001 2" OD on 6"R \$488.00
TSTA-2-1-0007 1 3/4" OD on 8"R \$573.00
TSTA-2-1-0005 1 3/4" OD on 6"R \$488.00
TSTA-2-1-0004 1 3/4" OD on 5"R \$462.00
TSTA-2-1-0012 1 5/8" OD on 8"R \$573.00
TSTA-2-1-0010 1 5/8" OD on 6"R \$488.00
TSTA-2-1-0009 1 5/8" OD on 5"R \$462.00
TSTA-2-1-0018 1 1/2" OD on 8"R \$573.00
TSTA-2-1-0016 1 1/2" OD on 6"R \$488.00
TSTA-2-1-0015 1 1/2" OD on 5"R \$462.00
TSTA-2-1-0014 1 1/2" OD on 4"R \$422.00
TSTA-2-1-0022 1 3/8" OD on 6"R \$484.00
TSTA-2-1-0021 1 3/8" OD on 5"R \$458.00
TSTA-2-1-0020 1 3/8" OD on 4"R \$422.00
TSTA-2-1-0028 1 1/4" OD on 6"R \$484.00
TSTA-2-1-0027 1 1/4" OD on 5"R \$458.00
TSTA-2-1-0026 1 1/4" OD on 4"R \$422.00
TSTA-2-1-0034 1" & 7/8" OD on 6"R \$497.00
TSTA-2-1-0033 1" & 7/8" OD on 5"R \$471.00
TSTA-2-1-0032 1" & 7/8" OD on 4"R \$461.00
TSTA-2-1-0031 1" & 7/8" OD on 3"R \$455.00
TSTA-2-1-0038 3/4" & 1/2" OD on 4"R \$461.00
TSTA-2-1-0037 3/4" & 1/2" OD on 3"R \$455.00

Die Sets Sold Separately

Other Die Sets available including:

- Round Tubing Dies
- Square Tubing Dies
- Pipe Dies

Bender Specifications

- Produces bends up to 180°
- Collapses in seconds and rolls away for easy storage
- Top quality American components
- Dies CNC machined from 6061 aluminum billet and hard anodized
- Bends round & square tube, bar stock and pipe (with correct die set)
- Bending capacity 1/2" to 2" OD
- Choice of foot controlled air pump or hand controlled unit
- Unique collapsing design provides a sturdy working platform
- Many options available to tailor the bender to your needs
- Optional custom dies available
- Accurate to within 1/4°
- Hydraulic powered



SUPER BENDER **RACING KIT**

Specifications:

Bends without an internal mandrel
Bending Angle degree from 0-180
Maximum bending radius 11.5" centerline
1 speed operation

Standard Equipment:

Digital numeric control
Equipped with a 1.8" and a 2" drive shaft for different tooling
New Automatic release system for faster operation timing

Capacities:

Pipe 1/4" to 1 1/2" (sch 40 grade A53 mild steel)
Tube 1/4" to 2" O.D.
Flat 1/8" x 3/8" to 3/8" x 1 7/8"

Motor: 1500 watt
Electric: 110V 1Ph 50/60 hz
Dimensions: 23 1/2" L x 10" W x 35 1/2" H

Overload protection system with warning light
Emergency Stop Button
Built-in wheels and extractable handle for easy mobility



**Super Bender Racing Kit
#MAC-0K60T
\$10,100.00**

Racing Kit Includes:

Part	Description	
060A	Super Bender machine 110V 1 Ph	
153R67-3/4"	Steel former for 3/4" tube with a .049 wall or greater at a 2.6" CLR	
154-3/4"	Brass counterbending die for 3/4" tube	
153R67-7/8"	Steel former for 7/8" tube with a .049 wall or greater at a 2.6" CLR	
154-7/8"	Brass counterbending die for 7/8" tube	
153R82-1"	Steel former for 1" tube with a .049 wall or greater at a 3.2" CLR	
154-1"	Brass counterbending die for 1" tube	
153R112-1 1/4"	Steel former for 1 1/4" tube with a .049 wall or greater at a 4.4" CLR	
154-1 1/4"	Brass counterbending die for 1 1/4" tube	
153R150-1 1/2"	Steel former for 1 1/2" tube with a .049 wall or greater at a 5.9" CLR	
154-1 1/2"	Brass counterbending die for 1 1/2" tube	
153R170-1 3/4"	Steel former for 1 3/4" tube with a .065 wall or greater at a 6.6" CLR	
154-1 3/4"	Brass counterbending die for 1 3/4" tube	

TUBING NOTCHER

Williams
LOWBUCK® TOOLS

The Williams Lowbuck Tubing Notcher is a must for any shop working with round tubing. In less than six seconds you can fish-mouth the end of a tube so it can be perfectly butted with another for welding. Cuts are clean and precise, requiring no grinding or guesswork.

Notchers are available with 4 sizes of cutters. Each size will notch various diameters of tubing without changing cutters. By swapping interchangeable cutters, one notcher will handle tubing from 1-inch to 2 1/2-inches. For 90° joints, take a full bite from each side of the tubing. For angles down to 60°, take a large bite from one side and a small bite from the other. For joints less than 60°, cut the tube at an angle and notch the sharp edge only.

These notchers are made of top quality materials and are designed to last a lifetime. The cutting edges are case hardened to 62 rockwell, so they need no resharpening. The unit comes cad plated, fully assembled, and is designed to bolt to the side of your workbench. Extra Interchangeable cutters are available.

Capacities: .125 wall mild steel or 4130 and up to schedule 40 pipe.

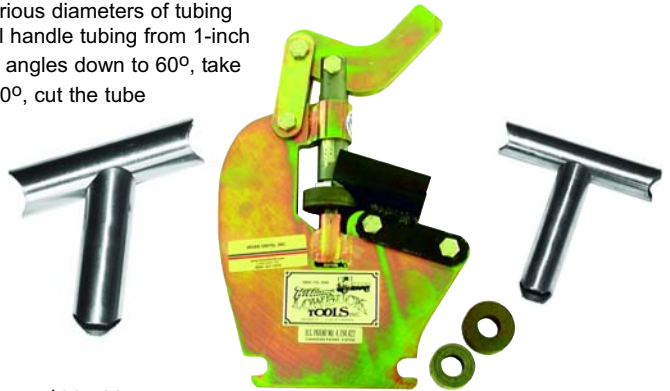

Tubing Notchers:

#1	LOW-1-TN 1" to 1 1/4"	\$325.00
#2	LOW-2-TN 1 1/4" to 1 7/8"	\$325.00
#3	LOW-3-TN 2" to 2 1/2" tubing or fence pipe notcher, not for schedule 40 .	\$325.00
#4	LOW-4-TN 1 3/8", 1 5/8", 1 7/8" fence pipe notcher, including schedule 40	\$325.00
Additional cutter sets (in above sizes)		\$120.00
Cutter Die Only (Measure Diameter of Die Before Ordering)		\$29.00

Replacement Parts available.
Patented in US and Canada

SHRINKERS AND STRETCHERS

Small, portable and lightweight, bolted to your workbench or stand the shrinker and stretcher can be used to form up to 16 ga aluminum, 18 ga mild steel or 20 ga stainless steel, bending a radius as small as three inches. They are ideal for making wheel wells, air cleaner shrouds, radiator shrouds and many otherwise hard to form shapes.

- Made with ductile iron
- Shrinks metal for inside angles
- Stretches metal for outside angles
- 45 to 1 powerful press leverage
- Mounts on bench, stand or in vise
- Specially hardened jaws reversible for double the life
- 10 lbs each
- 18 ga. soft steel capacity
- 20 ga. stainless capacity
- 16 ga. aluminum capacity



\$260.00 Combo

1 Body w/ 2 Jaws

\$350.00 pair

2 Complete Units

Sold Separately - \$180.00 ea.
Replacement Jaws - \$70.00

ECKOLD

Eckold is world renowned for making quality metal working tools. The Eckold Handformer Model HF80CH shrinker and stretcher is an invaluable tool for any serious metal craftsman.

Specifications

- Reach when shrinking and stretching - 3.150"
- Gap when shrinking and stretching - 2.362"
- Working capacity:
 - Steel of deep drawn quality - 0.059"
 - Light metal - 0.079"
 - Stainless steel - 0.059"
- Adjustable work height - 32.680" to 44.490"
- 69 lbs.

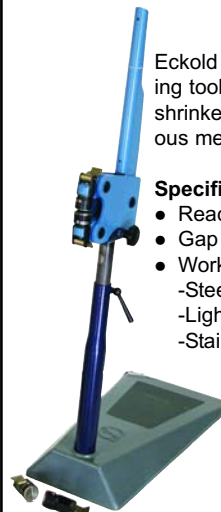

#HF80CH
\$2995.00

Replacement Parts Available.

HAND SHRINKER

Also known as a crimper, shrinks sheet metal by creating a wavy edge pattern. Excellent utility tool for shrinking in those tight spots.



#C5-CRIMPER
\$25.00

SHRINKER/STRETCHER STANDS



Shrinker/Stretch Stand

- 30 1/4" tall
- Holds both units and handles
- Powder Coated

#SHT-009-ISISH-ST
\$70.00

Foot Operated Shrinker/Stretch Stand

- Holds & operates both units
- Allows both hands to hold large panels
- Easily converts to use with handles
- Powder Coated
- Shrinker/Stretch sold separately

#SHT-FCS0701
\$275.00



Shrinker/Stretch not included

PIPEMASTER™ TUBE FITTING TOOLS

A Must for working with tubing!

The easiest & quickest way to fit tubes for welding. Place the tool at the joint and it takes the exact shape needed. Slide the tool over the tube and mark the shape of the joint for accurate notching.



Buy them individually or as a kit!

P-T075 3/4"	\$37.00 ea.
P-T0875 7/8"	\$38.00 ea.
P-T100 1"	\$39.00 ea.
P-T1125 1 1/8"	\$40.00 ea.
P-T1125 1 1/4"	\$41.00 ea.
P-T1375 1 3/8"	\$46.00 ea.
P-T150 1 1/2"	\$47.00 ea.
P-T1625 1 5/8"	\$46.00 ea.
P-T175 1 3/4"	\$51.00 ea.
P-T 1KITCU Pipemaster Kit w/ case (1", 1 1/4", 1 1/2", 1 3/4")	\$179.95 ea.

GUSSETS

Solid or Lightweight

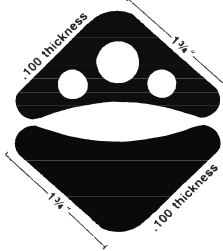

\$12.00 per 100
\$7.50 per 50
\$4.00 per 25

ENCO PLATE SHEARS



Cuts both plate and round stock

This shear is a great addition to any fab shop. Ever have to cut a piece of flat iron that was too long for your vertical band saw? Don't have a vertical band saw? This is the tool for you. Slices through that 1/8 inch flat bar that all racers use to build their cars. Clean, quiet, inexpensive, and fast.



Model	Capacity Round	Capacity Flat Bar	Length of Blade	Wt Lbs	Old Price	Price
130-5705	3/8"	2-3/4"x3/16"	5"	20	\$65.95	Now \$54.95
130-5710	7/16"	2-3/4"x1/4"	6"	40	\$77.95	Now \$64.95
130-5715	1/2"	2-3/4"x1/4"	8"	54	\$87.75	Now \$79.95
130-5700	1/2"	2-3/4"x1/4"	12"	100		\$109.95

BEVERLY SHEAR



	<u>MODEL B1</u>	<u>MODEL B2</u>	<u>MODEL B3</u>
Capacity:	14 ga. mild; 18 ga. SS	10 ga. mild; 14 ga. SS	3/16" mild; 10 ga. SS
Weight	18 lbs	35 lbs	58 lbs
Height less handle	14"	15"	15"
Handle	18"	24"	30"
Width	7"	9"	9"
Depth	9"	10"	14"
Lower Blade length	4 1/4"	4 3/8"	5 5/8"
Length of Cut	3"	3 1/8"	4 1/4"
Price	\$520.00	\$725.00	\$1050.00
Replacement Blades	.. \$86.00	.. \$112.00	.. \$156.00

Throatless Shears let you turn your work at any angle for straight, curved, even irregular cuts with ease and accuracy. Also means unlimited length of cut. Geared rack and pinion makes heavy metal cutting easy. Upper and lower blades are positioned to provide a clean, knurl-free cut, regardless of material. All models are equipped with high carbon, high chrome blades which can be replaced! Made in U.S.A.

The top Nascar Cup fabricators use this shear to cut everything from Lexan and stainless steel radiator screen, to stainless steel braided hose and thin aluminum crush panels. Very versatile and no shop should be without one.

Powered Pneumatic Beverly Shears available. Call for pricing and availability

OPTIONAL STAND

Designed to accommodate any Beverly hand-operated shear. Provides a safe, rigid, and very accessible base. All Steel, welded construction.

Weight 17 lbs.
 Height overall 30"
 Table Top 5" x 8"
 Floor Space Required 18" x 28.5"

\$135.00

Manufactured by ISI



ENGLISH WHEELS & PLANISHING HAMMERS

FLOOR MODEL ENGLISH WHEEL



BENCH ENGLISH WHEEL



- 44" welded machine
- Frame mounted on 3" casters for mobility
- Storage for anvil wheels
- Upper wheel is 8" dia. x 3" wide
- Anvil wheel is adjustable for throwing a flange and truing, etc.
- Includes: 6 anvil wheels with radii - 2.375, 3.25, 5.00, 8.50 12.00 & flat
- Upper wheel and anvils made from 1045 alloy steel and polished to a 63 finish
- Capacity: 18 ga. steel, 1/8" aluminum

Optional 1" radius anvil (2" wide) \$85.00

Was \$2595.00
Now \$2450.00



- Economical
 - Deep 22" throat & 2" wide anvils allow using a 44" panel.
 - Used for motorcycle gas tanks to race car body parts
 - Can be bolted permanently to any bench or clamped to a vise.
- Shipping Weight 67 lbs
Comes with 2 3/8" anvil

Optional Anvils
(Flat, 1", 3 1/4", 5", or 8 1/2")
\$85.00 ea.

Was \$599.00
Now \$499.00

HANDHELD ENGLISH WHEEL (AKA THE BILL WHEEL)



- Great for smoothing small wrinkles
- Easily stretches material for a little more tire clearance

#EGW-SLR-BW
\$495.00

U-WELD-IT-KIT



- All of the critical components of our floor model machine are supplied. you provide the metal for the frame.
- Use frame and assembly specifications in the supplied instruction booklet or use your own design!
- Features and capabilities are the same as the floor model unit.
- Includes 6 radius anvils
- YOU SUPPLY Steel Tubing
- Welding required
- Ships UPS 2 boxes 45 lbs ea.

Was \$1605.00
Now \$1505.00

RATCO PLANISHING HAMMER



Designed and built around a Chicago Pneumatic air motor, this unit is designed to give you years of trouble-free service.

It comes with 6 crowned dies and 1 flat upper hammer. The throat is 16" deep and the die post is 11" tall. Built for professional use but priced for the backyard hobbyist.

\$3595.00

QUICKSHAPER™ MARK II

- A multitask English wheel
- 32" throat English wheel
- Upper wheel and anvil can be turned 90°

Uses include:

- Hammering / Blocking
- Wheeling and raising metal panels
- Shrinking or stretching
- Planishing
- Comes with 6 anvils, 1 shrinker/stretcher combo unit, 1 forming head, 2 3/4 plastic mallet, 2 3/4 hickory mallet, flat wood slapper, 12" shot bag (unfilled) and DVD



FQSM2 Quickshaper™ Mark II **Was \$4599.00 Now \$4375.00**
FQSM2-06 Opt. Edging Anvil \$99.00
FQSM2-07 Opt. Deep Reach Anvil \$99.00

PROLINE PLANISHING HAMMERS

ProLine Planishing Hammers are designed for forming or planishing light gauge sheet metal shapes.

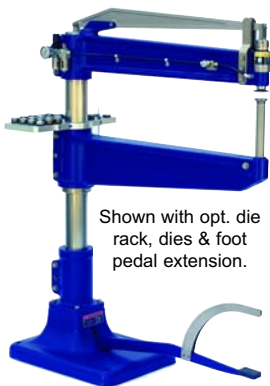

Shown with opt. die rack, dies & foot pedal extension.

- Finest grade cast iron frame.
- Air regulator with lubricator.
- 12-point Grade 8 bolts used throughout.
- Fine air control knob for easy operator adjustment.
- Optional die set available

#050096 24" Throat **\$6900.00**
#050095 36" Throat **\$8900.00**



- Handheld Set includes:
- 10 1/2 x 11 1/2 Cast aluminum yoke
 - Storage case
 - Dead blow hammer
 - Rubber top die
 - Linear stretch die
 - 9" Bottom die
 - Parts Box



#060007 Handheld **\$2895.00**



Made In The USA



T-DOLLIES

Form flanges and edges easily with these handy T-Dollies. Available in straight or curved models for those hard to form parts. Can be used with hammers or slappers. T-Dollies can be hand-held or placed in a vice.



- TPA5518 sm. 1/2" dia. x 4" . \$23.00
- TPA5519 med. 3/4" dia. x 6" \$26.00
- TPA5520 lg. 1" dia. x 8" . \$28.00
- HTD00 1" dia. x 3 1/4" . . \$23.00



- FCTD01 Gentle Curve . . \$49.50
- FCTD02 Crescent Curve \$46.50
- FCTD03 Slope Curve . . \$47.50



WOOD SLAPPERS

Made from top quality hard maple and lined with top grade leather on the face to eliminate marring of the metal. Available in 4 different shapes: flat, gentle, curved and round.

- FFS01 Flat slapper \$64.00
- GFS01 Gentle slapper \$64.00
- CFS01 Curved slapper \$64.00
- RBS01 Round slapper \$58.00
- RLF01 Repl. Leather face . . . \$15.00



SHAPING STATION

This Metal Shaping Station will become a focal point in any metal shop. Forming heads and post dollies help form simple and complex shapes. Station comes with 1 storage rack for holding up to 5 forming heads. With additional optional storage rack, this station can hold up to 9 forming heads.

- FMSS01 Metal Shaping Station . . \$269.00
- FMSS01P Post Dolly Adapter (opt.) . \$39.00
- FMSS01R Storage Rack (opt.) \$53.00



POST DOLLIES

POST® dollies are made of high quality cast iron and have a solid easy-grip handle. Designed by Ron Fournier, the one-piece casting includes flats on handle for convenient clamping. Dollies can be used as a handheld tool, in a vise, or use in the NEW Metal Shaping Station with the post dolly adapter.

Approx. size: 2 1/2"x4 1/2".

- PD001 Half football \$57.00
- PD002 Loaf \$57.00
- PD003 Teardrop \$57.00
- PD004 Shoe \$57.00

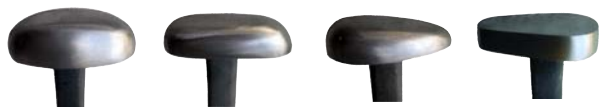

LEATHER PANEL BEATER BAGS

Stretch metal without nicks or gouges with these 6" or 18" round beater bag. The filled bag absorbs the hammer blows as you pound the sheet metal for a smooth finish. The 18" uses approx. 75 lbs of #9 lead shot that can be purchased at your local sporting goods stores.



- 6" Bag ~~\$22.50~~ **Now \$20.00**
- 18" Bag ~~\$54.50~~ **Now \$53.00**



FORMING HEADS

Just like the Post® Dollies, these Forming Heads are made from cast iron. Use them as cast or give them a quick finish with your sander. Larger and heavier than the Post® Dollies, these can be used in the Metal Shaping Station or a vice to form simple and complex shapes. Available in 6 different styles for unlimited shape possibilities. Approx. weight is 20 lbs. each.

- MFH01 Fender Maker 9"x4"x2" \$125.00
- MFH02 Bike Builder 8 1/2"x4 1/2"x2" . \$125.00
- MFH03 Tank Shaper 10 1/2"x4 1/2"x2" \$125.00
- MFH07 High Crown 4 3/4"x3 1/8"x3" . . \$98.00
- MFH08 Blunt Teardrop 6 1/2"x3"x2 1/2" . . \$98.00
- MFH09 Classic Bowl 7" dia.x2" \$125.00

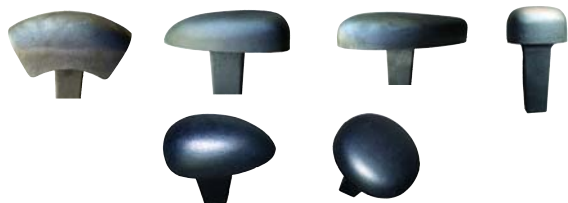

SUPER PLASTIC MALLETS



Polyethylene head, hardwood handle with brass wedge. Eliminates marring. Long life, split resistant.

- TPA5524 (2 1/2" dia. Bossing) **\$35.00**
- TPA5554 (2" dia. Doming) **\$30.00**

METAL SHAPING DVD

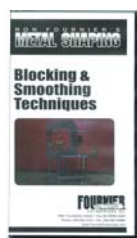

In this DVD, Ron Fournier explains his technique of blocking and smoothing aluminum parts using shot bags, mallets, forming heads, and slappers. Final smoothing is demonstrated on an English Wheel. A variety of shapes are made including: a bowl, teardrop, and motorcycle fender. Also, forming a section patch panel for a sports car fender using a buck is demonstrated. Thorough explanation of the tools and equipment used to form .050" aluminum and .063" aluminum makes this DVD a must have for any fabricator.

Run Time: Approximately 90 Minutes **\$35.00**

PRECISION AVIATION SNIPS

- Double-cam-action construction
- Designed for precision cutting
- Cuts circles, squares, and irregular patterns in all metals.
- Made in USA

KLENKS

Model KJ-1 - Red (LH)
\$21.00



Model KJ-2 - Green (RH)
\$21.00

Model KJ-3 - Yellow
(Straight)
\$21.00



OFFSET SNIPS



KOS-1 Offset - Red
(LH)
\$27.50

KOS-2 Offset - Green
(RH)
\$27.50



HAND SEAMERS



These hand seamers or hand brakes are a must for any sheet metal fabricator's tool box.

- S2 Straight 3" Wide **\$35.00**
- S3 Offset 3" Wide **\$37.50**
- S6 Straight 6" Wide **\$69.00**

ALUMINUM SNIPS

Strong and lightweight aluminum handles with inlaid steel blades. Perfect for cutting sheet metal, aluminum, and vinyl. These snips make very straight cuts with clean, crisp, exact edges.



#DA70060
~~Was \$40.00~~
NOW \$27.50
Replacement Blades
#DA74520
~~\$18.00~~ **NOW \$13.25**

TRANSFER PUNCH SET



Simple and effective way to mark the center of an existing hole onto a workpiece below. Perfect for the machinist or the sheet metal fabricator.

28 pc. set
#E-830-0099
\$18.00

PORTABLE POWER SHEARS



A double cut power shear for 18 ga. and lighter sheet metal. Cuts 180" per minute. Save up to 90% hand shearing time. The 7/32" waste curl leaves both sides of the cut straight and clean with no distortion. Deburring is unnecessary. The ideal tool for the tinner, roofer and the autobody shop. Excellent for ductwork and for aluminum and steel siding installation.



120V AC 3.2 Amp, 2500 rpm motor, weight 5 lbs, Overall length 11 3/4"

#KD-200
\$215.00
Replacement Blade Kit #K102
\$38.50

METAL FABRICATING BOOKS

By Ron Fournier
A must for any metal fabricating shop.
#HP575 Sheet Metal Handbook
#HP709 Metal Fabricator's Handbook
\$15.00 ea.



NATIONAL SPEEDWAY DIRECTORY



The book lists detailed information including the phone numbers, addresses, exact directions, nights of operation and type of racing.
\$7.00



**HOW TO
BECOME A
WINNING
CREW CHIEF
BY LARRY
MCREYNOLDS**

#1893618471
\$20.00 ea.

PUNCH & FLANGE TOOL

Campbell Hausfeld professional air tool works like step mandrels. Crimps 14 ga. sheet metal for smooth seams. Flip side of head punches 3/16" holes for spot welds. Head rotates 360°. Flange panels on or off car.



#PL1550
\$75.00

NIBBLER TOOL

Cuts soft sheet metal up to 18-ga. and plastic, soft copper and aluminum up to 1/16" and tubing from 1" I.D. with a squeeze of the handle. Ideal for sheet metal fabricating. This is the tool you need to make a round hole square.



#76011B
\$25.00

Replacement Blade #76012B
\$9.00

4 TON HAND NOTCHER

- Notch any shearable material
- Easy to Read
- Front Gauge
- Heavy Duty Blade

Enco

Model 130-5110
\$348.95
Stand 130-5115
\$157.95
Wt. 90 lbs.



Specifications

Capacity 4 tons
Material
Mild 16 ga.
Stainless 20 ga.
Max Notch 6"x6"x90°
Stroke 3/4"
Table Size 17"x12"
Weight 235 lbs

Roper Whitney HAND CORNER NOTCHER

Notches up to 1" deep
Max capacity 20 ga. Mild Steel

#541A
\$132.00



CORNERMATE NOTCHER



Notcher Table
#CM40A
\$89.00

The Cornermate® Series is the new standard for cutting corners, holes and slots. There are nine styles with over thirty interchangeable cutting units from 1/8" to 1". All units are precision engineered and manufactured from the finest materials and will produce flat, crisp shapes in flexible plastic, aluminum, brass and many other materials. Each cutting unit has the material guides machined into the body of the unit so the location of the cut is always the same.

To use, the cutting unit is placed in a machined recess in the table, the material is inserted into the cutting unit, and the handle is squeezed. It is that simple and that quick!

NOTCH

18N \$79.00
316N \$79.00
14N \$79.00
38N \$79.00
12N \$79.00
34N \$119.00
100N \$119.00

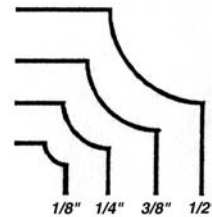

CHAMFER

14C \$89.00



ROUND

18R \$79.00
316R \$79.00
14R \$79.00
516R \$79.00
38R \$79.00
12R \$79.00
34R \$119.00
100R \$119.00

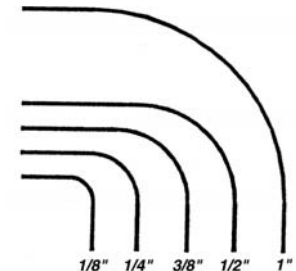

Trace-A-Punch®

Model	3C	4
Price	\$1,985.00	\$3,660.00
Cutting Capacity	1/8"	3/16"
Mild Steel	.125"	.186"
Plastic	3.175mm	4.725mm
Cutting Capacity	1/8"	1/8"
Stainless	.125"	.125"
Exotic Metals	3.175mm	3.175mm
Throat	6-3/4"	16"
Depth	171mm	406mm
Strokes per minute	1750	1200
Motor	1-1/2HP 110/220V 1 Phase - 50/60 HZ	3HP 220/460V 3 Phase - 50/60HZ
Weight	130 pounds - 59kg.	480 pounds - 218kg.

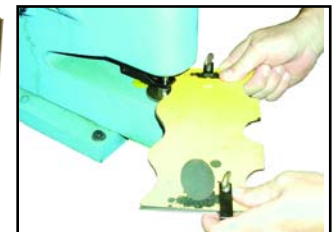
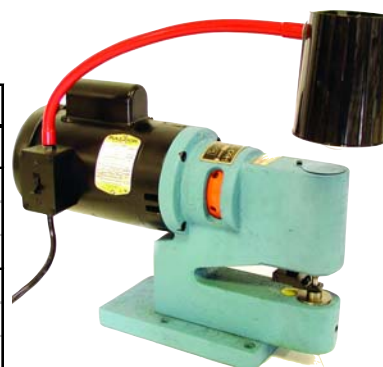

Easiest, most economical way to produce low production metal and plastic profiles. Trace-A-Punch® follows your guided template to produce burr free straight and contoured outlines and holes. Simple, rugged meehanite casting construction insures very little maintenance.

Cutaway view shows how the punch follows the outline of the master pattern. When the punch moves downward, the material is cut off in the shape of the master pattern.



PUNCH & FLARE



No hole saws necessary. Cuts and Flares in one easy step. May also be used as a hole punch only. Flare grows hole by 1/8".

Capacity 20 ga. steel or .050 alum.

Set of all 6 sizes.....	\$525.00		
1".....	\$90.00 ea.	1-3/4".....	\$100.00 ea.
1-1/4".....	\$90.00 ea.	2".....	\$110.00 ea.
1-1/2".....	\$100.00 ea.	2-1/2".....	\$110.00 ea.



HOLE FLARE



The right tool for the right job. Put the professional finishing touch on your race car. Adds strength while reducing weight on small or large pieces. Flare grows hole by 1/8".

Set of all 9 pieces.....	\$250.00
Small Flare Set 1/2" to 1 1/4".....	\$140.00 set
Large Flare Set 1 1/2" to 2 1/2".....	\$130.00 set
1/2", 5/8", 3/4", 1" or 1 1/4".....	\$30.00 ea.
1 1/2", 1 3/4", 2", or 2 1/2".....	\$35.00 ea.

KNOCKOUT PUNCHES



- Top of the line punches
- Production Quality
- Can be used manually or in a press
- 10 gauge capacity
- Smooth operation with thrust bearing design.

1/2".....	\$45.00 ea.	1 3/4".....	\$100.00 ea.
5/8".....	\$45.00 ea.	1 7/8".....	\$120.00 ea.
3/4".....	\$40.00 ea.	2".....	\$120.00 ea.
13/16".....	\$45.00 ea.	2 1/8".....	\$125.00 ea.
7/8".....	\$40.00 ea.	2 1/4".....	\$145.00 ea.
15/16".....	\$45.00 ea.	2 3/8".....	\$120.00 ea.
1".....	\$50.00 ea.	2 1/2".....	\$200.00 ea.
1 1/8".....	\$50.00 ea.	2 5/8".....	\$250.00 ea.
1 1/4".....	\$75.00 ea.	2 3/4".....	\$250.00 ea.
1 5/16".....	\$55.00 ea.	3".....	\$325.00 ea.
1 3/8".....	\$75.00 ea.	3 1/2".....	\$300.00 ea.
1 1/2".....	\$80.00 ea.	4".....	\$420.00 ea.
1 5/8".....	\$90.00 ea.	4 1/2".....	\$475.00 ea.

KLEIN-UNIBIT STEP DRILL BITS



Perfect for drilling multiple size holes in thin sections of metal, plastic and wood using a single bit. Each Klein-Unibit does the work of many drill bit sizes. Drills round holes in most metals up to 1/8" thick as well as plastic and wood. No center punching or pilot hole drilling is required on most sizes. The bits are easy to keep sharp, and hole size is easily determined by the diameter of the markings that are permanently laser-etched in the flute areas.

Part No.	59001	59002	59003	59005
Price	\$18.00	\$36.00	\$34.00	\$18.00
# Hole Sizes	13	8	9	6
Increments	1/32"	1/16"	1/16"	1/16"
Size Range	1/8" to 1/2"	9/16" to 1"	1/4" to 3/4"	3/16" to 1/2"
Pilot Hole Req'd	No	Yes, 1/2" & Up	No	No
Drill Size	1/4" & Up	1/2" & Up	3/8" & Up	1/4" & Up

LISTA

MAKING WORKSPACE WORK®
SINGLE MOBILE CABINET
COMBINATIONS

Each mobile tool cabinet comes with:

- two fixed and two swivel and lock heavy duty 6" casters
- tubular steel handles
- lock and two keys
- one-drawer-at-a-time safety system with individual drawer latches

Available with 100% full extension drawers with 440 lb. load capacity..

MP models have 95% extension drawers with 150 lb. load capacity; except drawer sizes 9" and above which are 100% extension and 440 lb. capacity.

All units are available in seven standard Lista colors.

Full extension drawers that glide open even with a full 440 lb. capacity

One-drawer-at-a-time safety system prevents tipping

Full width drawer handles are recessed, flush with the face of the housing to prevent snags



A variety of tops are available to create the work surface you need on top

A broad range of drawer partitioning accessories gives you customized storage based on your particular need

Individual drawer latches lock drawers closed for moving

2 swivel and 2 rigid 6" casters with a foot pedal lock that locks the wheel. 3600 lb. capacity

High Density Storage - Modular design and full sidewall height drawers give full cubic usability for tools or parts.

More Sizes and Shapes - From shallow depth to narrow, standard and mid-width, nobody offers more than Lista.

Maximum Flexibility - Drawer sizes range in height from 2" to 13" in 1" increments for a completely custom-configured cabinet.

Lifetime Warranty - Heavy gauge rugged steel construction provides years of durability. Ask your distributor for warranty details.

FOR CUSTOMIZED DRAWER COMBINATIONS, DRAWER PARTITIONING, STATIONARY CABINETS OR ACCESSORIES PLEASE CALL 1-800-221-7223



#QSHS900-2A

- 40 1/2" wide x 22 1/2" deep x 41 3/4" high
- 7 drawers, 96 drawer compartments
- painted Bright Blue standard, other colors available by special order
- shipping weight 450 lbs.

\$1471.49



#QSMP0750-0402

- 22 3/16" wide x 28 1/2" deep x 33 1/2" high
- 4 drawers, 29 drawer compartments
- no base
- shipping weight 225 lbs.

\$789.53



#QSHS900-1A

- 40 1/4" wide x 22 1/2" deep x 41 3/4" high
- 9 drawers, 117 drawer compartments
- painted Bright Blue standard, other colors available by special order
- shipping weight 500 lbs.

\$1625.70



#QSMP0750-0505

- 22 3/16" wide x 28 1/2" deep x 33 1/2" high
- 5 drawers, 41 drawer compartments
- no base
- shipping weight 225 lbs.

\$845.94

RW ROPER WHITNEY PUNCHES



Light Duty Portable Punches are for limited punching power (1.2 tons or less) They're easy to carry in the pocket, on a belt or in a tool box. Hardened machined bearing surfaces are used in these tools to provide dependable long life within the rated capacity.

- Maximum rated capacity 1.2 tons
- Smallest available
- Hand operation
- Adjustable stop gauge

The No. 5 Jr punch has a standard 1 3/4" throat depth while the No. XX has a deep throat configuration to punch up to 3 1/4" from the edge. The No. XX may be used to punch light channels with 1" minimum inside dimension and 1 3/8" maximum flange. Both punches have optional mounting bases and are also available as kits with a standard assortment of round punches and dies in a durable plastic box.



NO. 5 JR. KIT **\$75.00**

Kit includes: tool & one 3/32", 1/8", 5/32", 3/16", 7/32", 1/4" & 9/32" round punch & die in plastic box. Throat Depth = 1 3/4".

Optional Bench Mount - \$25.00

NO. XX KIT **\$215.00**

No. XX Kit includes: tool & one 5/32", 7/32", 9/32", 11/32", 13/32", 15/32", 17/32" round punch & die in plastic box. Throat Depth = 3 1/2".

Optional Bench Mount - \$40.00

Optional Punches Sold Separately



Call For Pricing

Made In The USA

RW FLOOR MODEL DEEP THROAT BENCH PUNCH NO. 218

This accurate punch is ideal for prototype, short production runs and model shops. The adjustable die shoe permits the proper alignment of close fitting punches and dies to accommodate very thin materials, as well as heavier stock. Optional cabinet base, and a 12" square gauge work table to extend the usefulness of the punch is available.

- Maximum Rated Capacity: 4 tons
- Linear Hand Operation
- Deep Throat (Punch holes up to 12" from edge of material)
- Work Heavy to Ultra Light Materials
- Comes with 1/2" round punch - other punches sold separately



No. 218 - **\$1204.00**
Optional Cabinet - **\$428.00**

BENCH PUNCH NO. 16

Medium Duty Bench Punch provides greater throat dimensions and a slightly broader range of punch and die sizes. The No. 16 has a solid forged frame. The punch has adjustable dies shoes to permit the proper alignment of close fitting punches and dies to punch light gauge materials. It has the option of a removable 6"x8" work table with stops to position materials in the tool.

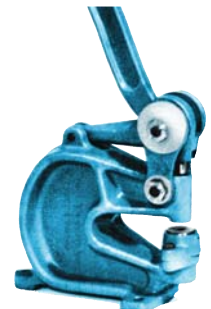

- Maximum Rated Capacity: 7.3 tons
- Linear Roller Bearing Cam Operation
- Standard Throat 3 1/4" Deep
- Works great on Spring Steel

No. 16 - **\$430.00**
Optional Work Table - **\$70.00**

Optional Punches Sold Separately



Call For Pricing

ROTEX PUNCH MODEL 20C 3.5*

The hottest and most popular punch on the market! Switch between 20 different punch sizes and types instantly by turning the turret. Saves time and money!

We usually have one of these high demand punches in stock, ready to ship.

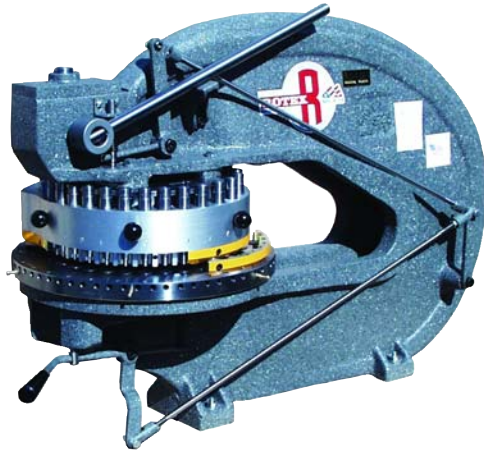

Specifications:

- 20 stations
- 26" throat depth
- 3 1/2" maximum hole punching capacity
- Rated at 15 tons
- Alphabet indicators align the punch and die station

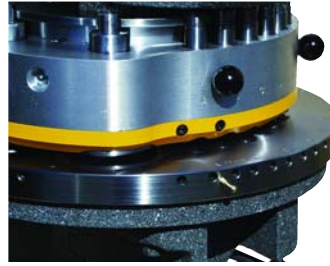

Tooling set includes: #30, #12, 7/32, 1/4, 9/32, 5/16, 3/8, 7/16, 1/2, 5/8, 3/4, 7/8, 1-1/8, 1-1/4, 1-1/2, 1-3/4, 2-1/2, 2-5/8, 3-1/2**

Bonus Tooling: 1" x 1/4" Oblong Slot installed in Station "N"

Call for current pricing

- * Other models and sizes also available
- ** Punches and Dies are available in a variety of shapes and sizes



Optional Stand
\$350.00

Uni-Hydro IRONWORKERS

Features

- Manual Punch Aligner (Model 42-14 & N42-14)
- 6" Open Throat Punch with 42 Tons of Punching Power
- Power Cavity Accommodates Various Tooling
- Fixed or Adjustable Bar Shear Holddown
- Forklift Accommodations
- Magnetic Starter for Safety and Reliability
- Variable Stroke control
- Built-In Square Notcher (Model N42-14 Only)
- One Year Warranty on 14" Bar Shear Blades
- Low Rake on Bar Shear for Excellent Cut
- 14" Bar Shear with 4-sided blades

Optional Tooling

- **PUNCH STATION**
Square notcher
Coper notcher
Pipe notcher
Brake: 6"
- **POWER CAVITY**
Square notcher
Coper notcher
Brake: 6" or 9"
Angle shear
Channel shear
Rod shear (Round or square)
Z & T shear

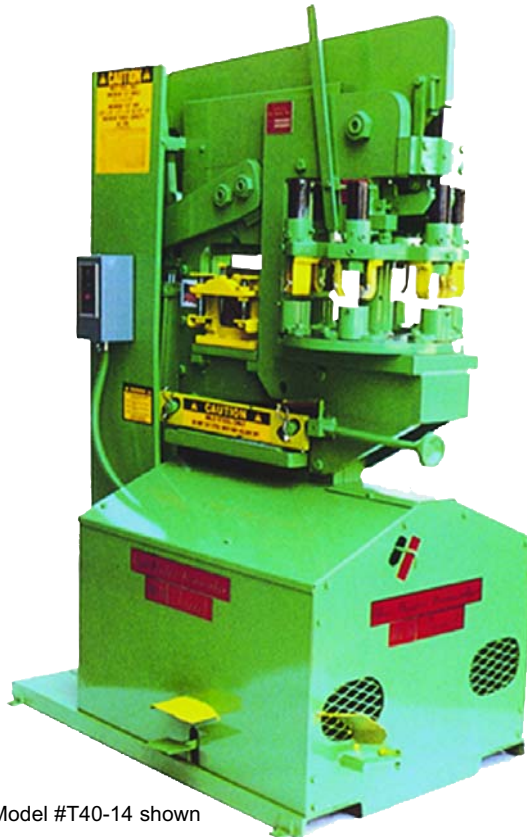

Model #T40-14 shown

Call for current pricing

SPECIFICATIONS	MODEL
	42-14, 42-14 SLS, N42-14
Throat Depth	6"
Punch	42 Ton 1-1/16" in 1/2" 1-3/8" hole in 3/8"
Bar Shear	3/8" x 1/4", 1/2" x 10", 5/8" x 6"
Angle Shear 90°	
Slug Type	
Standard Blade	3" x 3" x 3/8"
Special Blade	3" x 3" x 3/8"
Sever Cut	3" x 3" x 1/4"
Mitre Angle 90°	
Bar Shear	3" x 3" x 5/16"
Slug Type	2" x 2" x 5/16"
Channel Shear	2" or 3" standard
Rod Shear	
Round (Max)	3/4"
Square (Max)	3/4"
Coper Notcher 90°	For 3" x 3" x 1/4" Angle
Square Notcher	1-3/4" x 2" x 1/4"
Built-in Square Notcher (4th Station) (N42-14 Only)	1-3/4" x 2" x 1/4"
Pipe Notcher	
Sch. 40 or 80	1/2", 3/4", 1", 1-1/4", 1-1/2"
Brake	6" or 9" x 1/4"
Stroke per minute	
Light Material	50
Maximum Capacity	9
Hydraulics	1000 PSI
Oil Capacity	15 qt
Motor	
Standard	3 HP, 3ph
Optional	3 HP, 1ph
Dimensions	
Width	28"
Length	34"
Height	60"
Bar Shear Working Height	29"
Punch Table top height	38-1/4"
Cavity table top height	37-1/2"
Notcher Station working height	22"
Weight (Net)	1300 lbs (N42-14) 1240 lbs (42-14) 1205 lbs (42-14 SLS)

BELL HOUSING INDICATOR



- Indicates total run-out of bell housing centerline to crank
 - Eliminates pilot bushing, clutch engagement, shifting and transmission from bearing problems
 - Will need to know your transmission application for example GM-Fine, GM-Coarse, Ford-Fine
- \$80.00** with indicator
\$59.00 w/o indicator

DIAL INDICATORS



- 1" Travel
\$21.00 ea.
- 2" Travel
\$50.00 ea.
(.001 graduations)

DIAL CALIPERS

MANUAL DIAL CALIPER

Features:

- Direct Reading to 0.001 on large clear dial
- Measuring face hardened, precision ground and micro lapped for absolute accuracy
- Adjusting slide for fine adjustment
- Made of Stainless Steel
- Satin chrome finish; Crisp engraved graduation
- Clamp for repetitive measuring
- Deluxe Case
- Accurate to 0.001 per 6"
- Covered rack



#920-216
\$25.00



DIGITAL DIAL CALIPERS

6" x .001 increments Inch/mm units



#920-296
\$50.00



BRAKE FLUID

Hi-Temp 570° comes in convenient 12 ounce containers hermetically sealed to guarantee against unwanted absorption of moisture which can drastically lower the fluids boiling point (fluid from larger containers tends to become contaminated with moisture, lowering its boiling point and making it unsuitable for racing applications).

#290-0632 12 oz. bottle
\$5.00 ea.



SAFETY WIRE AND PLIERS

Automatic return, spring locking pliers used especially for turning safety wire into even twists. 2 sizes available:

- 6" O.A.L. - **\$29.95**
9" O.A.L. - **\$29.95**



Every race car needs safety wire. It is the only way to be 100% sure that a fastener will not come loose.

One pound size of corrosion resistant stainless steel safety wire in dispensing package. Wire uncoils from inside thru hole in top of dispenser. Avoids wild uncoiling, handles easier and faster. 1 lb. Sizes in .032 and .025

\$15.00 per 1 lb. can



DRILL FIXTURE

If you're tired of breaking bit after bit trying to drill a safety wire hole in a bolt head, we have the solution for you!

CNC made from billet aluminum. Safely allows you to drill safety wire tie holes in #10 through 5/8" bolts. Works on hex head or socket head capscrews. Includes 2 drill bits and 2 guide locks.

Was \$50.00 NOW \$39.95

MAGNETIC HEATER

Heats oil in lines, filter, and oil pan before starting engine. Many other uses.



3 3/4" x 2 1/4"
110V/200 W
300°-400°F
#1153 **\$40.00**

5" x 4"
110V/300 W
300°-400°F
#1160 **\$60.00**

SILICON HEATING PAD

4" x 5" pad heats oil tank, filter, and oil pan before starting engine. Many other uses. 6ft cord.

120V 250 Watt / 250°F



#24250 **\$42.00**

BRAIDED HOSE CUTTER

Cuts every strand neatly. No more frayed ends. Cutter also indents ends, making it very easy to get the fitting on. Cuts up to #16 hose.



\$110.00

#63081 Replacement Blades - \$94.00

TIRE BEAD BREAKER

Works on 15" wheels. Can be modified for smaller wheels.



\$45.00

TIRE MARKERS

Throw away the yellow chalk!!



This pen permanently marks on any slick surface. Racers find it ideal for marking tires.

\$2.50 ea.

SD-20

MULTI PURPOSE CLEANER & DEGREASER

Finally a cleaner that takes tire rubber off without smearing!

Ever tried cleaning tire rubber off your race car with brake cleaner? Makes a nasty mess. This product is used by the Cup teams to clean tire rubber, oil and grease from their cars without the mess! Try it once and you'll never use anything else!

\$4.50 per 18 oz. aerosol can
\$48.60 per 12 ct. case
\$10.00 per gallon



HOOD PIN HARDWARE



Pins 3/8" steel hood pins 2", 3", 4" or 5" length	\$2.50 ea.
Plates 3/8" steel hood pin plates	\$1.25 ea.
Clips	\$1.00 ea.
Sleeve 3/8" threaded 3/4" long (bosses)	\$1.75 ea.
Cables 24"	\$2.50 ea.

HOOD PIN PLATE DIMPLER

Recess your hood for 1 5/8" O.D. hood pin plates with 3/8" I.D.

\$32.00 set



SMART LEVEL PRO 360

Sunlight viewable LCD, reads and displays a full 360° and has a hold button to freeze the display.



iSeries levels have an alternate zero setting feature. It also has a "V" groove in the bottom on its aluminum rails. Easily calibrated and has an auto shut-off feature.

Use it for setting up trailing and control arm angles or spoiler angles. Many other uses.

\$200.00 Pro 360 reads .1°

\$345.00 Pro 3600 reads .01°

SMART TOOL ANGLE FINDER



- Digitally reads all angles in degrees, % slope and pitch
- Beeps at level and plum
- Push button recalibration
- 6 1/2" Length

#505-1893
\$100.00



phase II

ULTRASONIC HARDNESS TESTER MET-U1

Non-Destructive!

The PHASE II ultrasonic hardness testers are capable of measuring the surface hardness of a broad variety of metals on flat, round, thin or large surfaces. Accurate measurements of steel, cast steel, alloy steel, gray cast iron, cast iron, cast aluminum alloy, brass, bronze and copper are easily attained with this compact instrument.

- Meets ASTM A1038-05 specifications.
- Easy to read menu operation
- Large LCD Display with backlight
- USB interface
- Custom carry case
- Battery charger



#MET-U1 **\$3995.00**

phase II

ULTRASONIC THICKNESS GAUGE



The use of Ultrasonic non-destructive testing (NDT) to check material properties and the ability to gauge thickness measurement without requiring access to both sides of the test piece. Metals, plastics, ceramics, glass and other materials can easily be measured by portable ultrasonic thickness gauges with a common accuracy of .001".

- Custom carry case
- Certificate of calibration
- Operation manual

#UTG-2000 **\$795.00**

PIT WAGON SPINDLE KITS

STANDARD FRONT SPINDLE KIT



3/4" Spindle Shaft
Rear Axle Not Included
\$215.00

HEAVY DUTY FRONT & REAR SPINDLE KIT

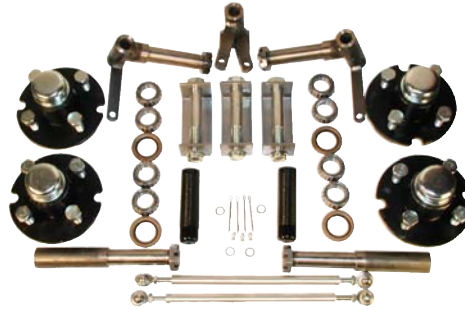

1" spindle shaft, tapered roller bearings & high speed hubs.
\$325.00

HEAVY DUTY 4 WHEEL STEER SPINDLE KIT



Same as Heavy Duty Spindle Kit but allows for steering the front and rear of your wagon or cart.
\$450.00

PIT WAGON TIRES & WHEELS



Polished aluminum 4 hole wheels w/ tire, lug bolts and chrome center cap
\$140.00 ea.
Wheel Alone - \$110.00 ea.
Chrome Center Cap - \$5.00 ea.
Chrome Wheel Bolts \$2.00 ea.



Steel 4 hole wheel & tire used on our wagons and with our HD front and rear spindle kits.
6-Ply 16.6" O.D. 745 lb. Capacity
DM408C-4I - **\$40.00 ea.**

WHEEL COVERS STAINLESS STEEL WHEEL COVERS & INSERTS

Separate stainless steel covers and multiple color inserts are available to fit our 4 hole tire and wheel.



SS-1 Cover - **\$15.00** ea.

Color Inserts - **\$5.00** ea.

(Specify Color: red, black, white)



TRIGGER LATCHES

Die Cast Zinc latches available with black powder coating or chrome
Requires 1" x 3 3/8" cut out.

- #C2-33-15Black Powder Coated Latch..... **\$10.00** ea.
- #C2-33-11Chrome Latch **\$14.00** ea.
- #C2-33-25-3Latch w/ Locks **\$17.00** ea.

HANDLE GRIPS

1" ID x 4 5/8" long for Spindle Kit Handles
or
7/8" ID x 4 5/8" long for Brake Kit Handles
\$2.00 ea.



SOCKET AND PLUNGER

Handle holder for securing the handle to your pit cart, trailer door, or anything else that needs to be held solid.

Parts sold separately.

- #PDH-100-C Powder Coated Plunger Socket ... **\$5.00** ea.
- #PDH-101Rubber Insert **\$5.00** ea.
- #PDH-318-C Powder Coated Door Plunger **\$7.00** ea.



PIT WAGONS

Irvan-Smith, Inc. is famous for manufacturing a full line of pit wagons with numerous options and features that are suited to a wide variety of racing.

Standard Features for our wagons include:

- Heavy 1/8" thick diamond plate top. Perfect for mounting a seat
- Durable powder coated inner frame
- Shelf floor made from strong .090 thick aluminum

- Each door equipped with powder coated trigger latches
- Doors and sides made from durable prepainted .040 aluminum with red, black, and white colors in stock. Other colors are available special order
- Steering uses tie rods and individual pivots with built-in Ackerman geometry to make the wagon easy to pull and turn

CUSTOM WAGONS AVAILABLE...Call us with your specific needs!

TOOLBOX WAGON

	L	W	H
Box	51"	34"	36"
Overall	79.5"	34"	54"
Toolbox Space	31.75"	23"	

Holds 2 nitrogen bottles



Wagon Only
~~\$2575.00~~
NOW \$2300.00

With Optional Toolbox (Lista ST750)
~~\$3570.00~~
NOW \$3400.00

Optional Side Skirts and Rear Door
\$250.00

Tool Box Sold Separately
\$1137.38



LARGE TOOLBOX WAGON

	L	W	H	Wagon Only
Box	77"	34"	67"	\$3995.00 NOW \$3500.00
Overall	79.5"	34"	71"	With Optional Toolbox (Lista HS600)
ToolBox Space	40.5"	42.25"	22.5"	\$4790.00 NOW \$4500.00

Holds 2 nitrogen bottles



Tool Box Sold Separately
\$1008.00

U-SKIN-IT WAGON

(Heavy Duty)



Can carry 2 nitrogen bottles. Rolling frame comes unpainted with heavy duty spindles and steering. Also includes weld on panel fastener plates and instructions for floor pans and exterior panels and doors. (shipping weight 240 lbs.)

	Length	Width	Height	
Box	72"	32"	47"	\$1150.00
Overall	79"	32"	51"	



BRAKE KIT

For Pit Wagons

Ever had trouble stopping your heavy pit wagon? We have the solution! Our disc brake kit will give you the power to stop your wagon.

Includes handle mounted master cylinder, 2 aluminum hubs with rotors, 2 aluminum calipers, 2 spindles with caliper mounts. Does not include brake lines.

\$875.00

Optional Brake Line Kits - \$97.50

Brake Fluid on Pg 20

BOTTOM FRAME

With heavy duty front and rear suspension
Overall Length 76 1/2"
Overall Width 34"



\$995.00



PIT WAGON COVER



- Durable Vinyl
- Zippers on all 4 corners
- Cutout for steering wheels
- Specify Color

\$400.00 ea.



PIT CARTS

- 3 wheel, air inflated tires
- lift off front wheel assembly for easy storage
- .090 aluminum floor pan
- 1" steel square tubing
- Powder coated frame
- Short turning radius.
- Can hold 4 race tires (depending on make), several full size rear end gears or just about anything else you need to haul around the track.
- Optional removable side mounted gas can restraints
- (Can Be Shipped UPS - Oversize shipping charges apply.)



Inside measurements
22"x54"x4.5"

Gas Can Restraint

- #PC-1 Without gas can restraints. **\$415.00**
- #PC-2 With gas can restraints. **\$450.00**
- #GAS-1 Gas Can Restraints. **\$32.50 pr.**



Inside dimensions
24 1/2" x 56"
Load height 6 1/2" from ground

55 GAL. DRUM CART

- Easily carry up to 2 55 gallon drums
- Comes unpainted

#PC-1-55 55 Gal. Drum Cart **\$450.00**

GAS CART

(NASCAR Approved)

- Holds 3 NASCAR approved fuel dump cans.
- Powder coated finish
- Removable front wheel assembly for easy storage on your hauler
- (Can Be Shipped UPS - Oversize shipping charges apply.)

#PC-3 \$415.00



FRONT WHEEL KIT FOR CARTS

Perfect for adding wheels to your electric generator or anything you need to make mobile.

Includes:

- Top plate & braces
- Front hoop
- 3/4" front axle and spacers
- Cotter pins & washers
- T-handle top
- 2 handle grips.
- Uses tire part #354DC or #354DB (not included) located on page 26.

\$95.00



TIRE RACK

- Holds up to 12 NASCAR Cup tires or 16 wheels.
- Powder coated frame.
- Optional nitrogen bottle rack available. Attaches to back of tire rack
- Truck Freight Only



#TR-1
\$425.00

Overall dimensions
92"L x 26" W x 59" H
Height Approx. 72" with tires

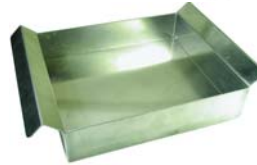

Optional Storage Tray
12x13.5x3
\$50.00



Optional Nitrogen Bottle Rack
#NB-1 \$50.00

TIRE RACK

DO-IT-YOURSELF KIT

Includes :

- 2 end frames (1 with t-handle)
- Handle pin & cable
- 2 handle grips
- 2 front caster plates
- 6 braces
- Rear axle with cotter pins & washers
- 2 #354FS-4 Swivel casters
- 2 #354DB tires z7 wheels and instructions
- You furnish 1 1/2" square tubing rails
- Welding Required
- Can be shipped UPS

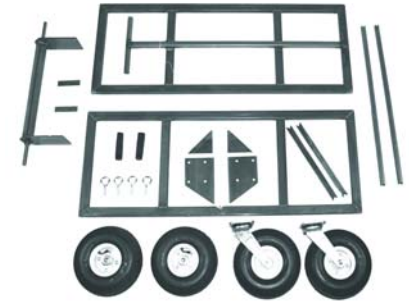

\$300.00

TIRE CARTS

- Powder coated steel
- Air inflated tires
- Will transport 4 NASCAR Cup tires & wheels on any ground surface.
- Can be shipped UPS - Oversize charge added



#TC-1 \$395.00

Can be used as a gas can carrier



#TC-2 \$445.00

No Tip Cart -- no need to tip a stack of tires to get under them.

ISI BUMP STEER GAUGE

Used by a majority of NASCAR Teams! Also for ASA, All Pro, Late Model, & Modified with independent suspension.



Bump steer in a race car should be minimized because it could fight everything that the driver is trying to accomplish with the steering wheel. In general, the rougher the track's surface, the more important it is to minimize bump steer.

This can be accomplished with our bump steer gauge. Comes complete with excellent instructions and aluminum storage box.

1" Tra Inside dimensions 24 1/2" x 56"
2" Tra Load height 6 1/2" from ground

MA BU GA

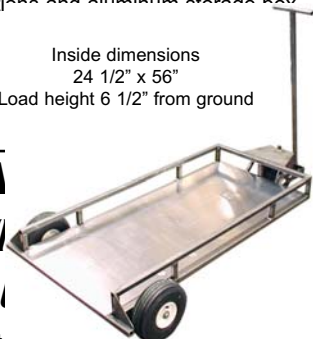

55 GAL. DRUM CART

- Easily carry up to 2 55 gallon drums
- Comes unpainted



This unit consists of a magnetic base that attaches to the frame rail. Each base has a 1" dial indicator. The aluminum hub plate and scale fits many hub styles. Use your own floor jack. This unit stores in a small metal toolbox which is included.



OVR-BS1MAG Magnetic Bump Steer Gauge **\$275.00 ea.**

DUMP CAN STAND

- Holds dump cans upright
- Collapsible for easy storage
- Comes unpainted

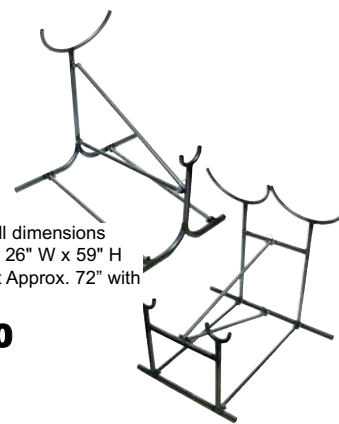

Overall dimensions
92"L x 26" W x 59" H
Height Approx. 72" with tires

#DCS-1 Single **\$110**
#DCS-2 Double **\$135.00**

FUEL TRANSFER PUMP

The Irvan-Smith air powered fuel transfer pump is an excellent alternative to dangerous 12V battery powered or 110V pumps.



- No more sparks
- Air operated
- Safe and efficient
- 3 GPM at 100 psi Max
- 6' suction lift
- Uses #8 braided hose
- Viton balls and Diaphragm
- Available with aluminum box and hose

#FP-60 Complete **\$750.00** #FP-50 W/O Hose **\$625.00**
#FP-55 W/O Box **\$675.00** #FP-45 W/O Hose & Box **\$575.00**

RIDE HEIGHT GAUGE

With the Quick Check Gauge you can easily and accurately measure all 4 corners of your race car without ever getting under the car.



#900 9" Gauge **\$300.00**
#1500 15" Gauge **\$150.00 ea.**



3 PUMP RACE JACK

Do you still lug that heavy jack around? A three pump version for faster pit stops. Precision CNC machined from aircraft grade billet aluminum. Manufactured in the USA by Brunnhoelzl. Colors - Red, Black and Blue.

\$550.00

DIRT SKIRT

Dirt skirt sold separately convert any Brunnhoelzl jack into a jack suitable for using on soft ground without sinking. Perfect for grassy or dirt pits.

\$79.95

DIRT WINGS

any
#TC-1 **\$395.00**
Can be used as a gas can carrier



NEW!

#TC-2 **\$445.00**

No Tip Cart -- no need to tip a stack of tires to get under them.

BLUEBIRD KNOCKDOWN ENGINE LIFT

KAYDEE 1200 Long Reach Lift

Kaydee Knockdown Lifts can be quickly taken apart, moved and assembled. Stores conveniently in your hauler. Used on most NASCAR Cup teams. A must at the race track.



#KD-1200
\$969.95

3 Ton Replacement Jack
#4351-JACK
\$300.00



AIR INFLATED TIRE AND WHEEL

Used on Pit Carts, Wagons, Etc.

Replacement Tire and Tube Available

Part #	Size	Ply	Weight Cap.	O.D.	Price
Available in 3/8"-3/4" Ball Bearings - Please Specify					
354DC	410/350-4	2	250 lbs.	10.6"	\$21.00
354DB	410/350-4	4	390 lbs.	10.6"	\$27.50

Available in 3/4" Open Cage Roller Bearing

356DB	410/350-6	4	495 lbs.	12.6"	\$45.00
409DC3-WRB	480-8	6	760 lbs.	16.6"	\$45.00

AIR INFLATED TIRE AND SPOKED WHEEL



Used on carts etc. needing high wheels

Size 20" x 2.125" - Stud Tread -
Hub Bore: 5/8" or 3/4" ball bearing
Hub Length - 3-7/16"

Wt. Cap - 150 lbs.

#SP20PSI-34BB
\$45.00

Replacement Tire and Tube available

PLATE-TYPE CASTER TIRE



Air Inflated

Top Plate on Rigid: 4" x 5.5"

Top Plate on Swivel: 4" x 4.5"

Part #	Size	Ht.	Weight Cap.	Type	Price
354FR-4	410/350-4	11 9/16"	250 lbs.	Rigid	\$45.00
354FS-4	410/350-4	11 9/16"	250 lbs.	Swivel	\$50.00

Replacement Tires and Tubes available

SOLID PLATE-TYPE CASTER TIRE



(Phenolic)

Top Plate: 4" x 4.5"

Part #	Size	Ht	Weight Cap.	Type	Price
4-4108-338	4 x 2	5 5/8"	750 lbs.	Rigid	\$17.50
4-4109-338	4 x 2	5 5/8"	750 lbs.	Swivel	\$22.50
4-6108-338	6 x 2	7 1/2"	900 lbs.	Rigid	\$20.00
4-6109-338	6 x 2	7 1/2"	900 lbs.	Swivel	\$25.00

RATCHET STRAPS AND ACCESSORIES



Don't start off your race day by unloading a wrecked car from your trailer!
Make sure your car is tied down properly with M & R ratchet straps and accessories!

ALUMINUM LOAD TRACK & FITTINGS

80467-12	Load Track 12'	\$62.50 ea.
80467-6	Load Track 6'	\$33.50 ea.
80467-3	Load Track 3'	\$17.95 ea.
80467-1	Load Track 1'	\$6.50 ea.
40890-02	Single Stud Fitting 4000 lbs.	\$6.95 ea.
47566-11	Double Stud Fitting 5000 lbs.	\$8.25 ea.
43949-10	Double Stud Fitting 7500 lbs.	\$9.25 ea.



SAFETY CHAINS

87903-15	1/4" class 3 - 5' "S" hooks 5000 lbs.	\$8.25 ea.
87903-16	1/4" class 3 - 6' "S" hooks 5000 lbs.	\$9.25 ea.

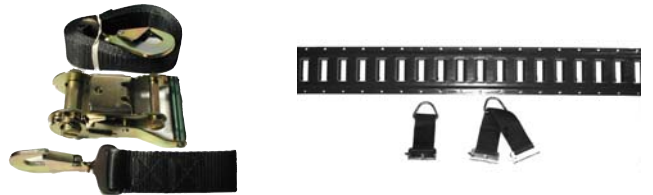

TIE DOWN STRAPS

80810-12B	1" ratchet strap, "S" hooks 10' 1200 lbs	\$9.50 ea.
80978-11BS	2" axle strap "D" ring 21" w/ sleeve 5000 lbs	\$8.50 ea.
83350-33B	2" ratchet strap, twist snap hook 6' 5000 lbs	\$25.50 ea.
83350-35B	2" ratchet strap, twist snap hook 10' 5000 lbs	\$27.50 ea.

"E" TRACK TIE DOWN ANCHORS

40837-05	"E" Track 5'	\$12.95 ea.
80386-11B	"E" adapter strap, single leg 3500 lbs	\$6.00 ea.
80386-21B	"E" strap, double leg 5000 lbs	\$8.50 ea.

TIE DOWN ANCHORS

44545-10	"D" ring, flush mount anti rattle 1200 lbs	\$3.95 ea.
80138-10	"D" ring, round 2" heavy duty 16,200 lbs	\$7.00 ea.
80138-20	"D" ring, recessed pan heavy duty 16,200 lbs	\$14.00 ea.
80140-10P	"D" ring round, flush mount 2 ea. 2000 lbs	\$5.00 pr.
80849-12	"D" ring, recessed galvanized 5000 lbs	\$7.50 ea.
82025-10	"D" ring square with roller 1000 lbs	\$9.50 ea.



POP-UP CANOPIES

This lightweight canopy is easier to raise/lower and more durable than other more expensive canopies on the market.

ECONOMY 10' x 10'

- Most Popular and Economical Shelters
- Lightweight Patented H/D Powder-Coated Rust Resistant Steel Frame

ECONOMY TOP 10' x 10'

- 250 Denier Polyester Fabric
- Water Resistant, UV-Treated
- Available in Blue or White
- All canopies come with Cover Bag, Stakes and Bungee Cords

#L610 ECONOMY 10' X 10' CANOPY **\$289.00**



Tired of Banging Your Head?
High Enough To Handle Most Any Need

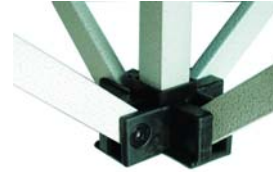

Highly Advanced Reinforced
Fiberglass Compound Pivots

STANDARD 10' x 15' & 10' x 20'

- With Powder-Coated Frame
- Heavy-duty Steel Construction
- Over 7.8ft. Canopy Clearance
- Durable, Reinforced Truss

STANDARD TOP 10' x 15' & 10' x 20'

- 500 Denier Polyester Fabric
- Water Resistant, UV-Treated
- Available in Standard Colors: White, Red, Blue, Green, Yellow, & Black
- Available in Custom Colors
- Custom Graphics Available
- All canopies come with Cover Bag, Stakes and Bungee Cords

#PL40 STANDARD 10 X 10 CANOPY **\$425.00**

#PL15 STANDARD 10' X 15' CANOPY **\$575.00**

#PL20 STANDARD 10' X 20' CANOPY **\$750.00**



Opens and Closes Easily with 2 People



Patented Pull Pin Slider Action
No Sticky Buttons To Push



**Side Walls and
Zipper Doors
Available**

**Call For Custom
Screen Printing
of Logos**

ALUMINUM CANOPY 10'X10', 10'X15', 10'X20'

- Anodized High Strength All Aluminum Construction
- Durable Reinforced Truss
- Lightweight and easy to carry
- 500 Denier Polyester Fabric
- Water Resistant, UV-Treated
- Available in Standard Colors: White, Red, Blue, Green, Yellow, & Black
- Available in Custom Colors
- Custom Graphics Available
- All canopies come with Cover Bag, Stakes and Bungee Cords

#TM10 ALUMINUM 10' X 10' CANOPY **\$495.00**

#TM15 ALUMINUM 10' X 15' CANOPY **\$675.00**

#TM20 ALUMINUM 10' X 20' CANOPY **\$850.00**

COOLDRAFT® PORTABLE MISTING SYSTEM

Add Water...Then Turn it on. It's That Easy!

The 10 gallon portable misting system is based on a patented concept, which allows the unit to operate unattended for up to 5 hours. COOLDRAFT® delivers 2000 cubic feet per minute of a fine mist propelled vapor, cooling up to a 200 square foot area. Ice can be added to the cooler to boost the cooling effects. Each unit is shipped complete with the misting head and Igloo's best 10 gallon cooler. It is fully warranted for 12 months against defect in materials or workmanship.

\$595.00



Longacre



NEW!

Irvan-Smith, Inc. is an authorized Longacre dealer.
Call us for their complete color catalog.

1-800-221-7223

Wireless Scales - Here's the ultimate in convenience



#72710

ECONOMY WIRELESS COMPUTER SCALES #72700

- Accuset control box with ZigBee Wireless receiver
- CNC Machined 15" low profile scale pads with handles and recessed connectors
- 1/10% accuracy and 1500 lbs per pad capacity
- 2 year limited Warranty
- (No roll around cart)

List \$1795.00

ISI Price **\$1678.35**

WIRELESS COMPUTER SCALES #72710

- Compact Control box with ZigBee wireless receiver just like our other systems- Push one button to turn it on
- Includes a roll around scale pad cart for easy transportation and safe storage
- 4 individual wheel weight displays
- Large 4 line display for all partial % and weights easily customized to your preferences
- Instant recall Memory for 8 complete setups
- Dead flat 15" CNC Machined pads with built-in ZigBee transmitters
- 1/10% accuracy and 1500 lbs per pad capacity
- 2 year limited Warranty

List \$2390.00

ISI Price **\$2234.65**

Wireless Computer Scales use the very latest ZigBee wireless protocol for the ultimate in security and reliability. Power consumption is so low the batteries only need to be changed once a season or even less. Transmitters are completely enclosed inside the pads for protection. No antennas to knock off, no modules dangling off the side.

WIRELESS COMPUTER SCALES #72724

- Compact Control box with ZigBee wireless receiver just like our other systems- Push one button to turn it on
- Includes a roll around scale pad cart for easy transportation and safe storage
- 4 individual wheel weight displays
- Large 4 line display for all partial % and weights easily customized to your preferences
- Instant recall Memory for 8 complete setups
- "NEW" Dual Load Cell Dead Flat CNC Machined 15" pads with built-in ZigBee transmitters
- 1/10% accuracy and 1500 lbs per pad capacity
- 2 year limited Warranty

List \$2980.00

ISI Price **\$2786.30**

COMPUTER SCALES #72634

- Premium Yellow Cables and luggage grade silver carrying case
- Shows all the wheel weights and All partial % at the same time
- CNC Machined 15" low profile scale pads with handles and recessed connectors
- 1/10% accuracy and 1500 lbs per pad capacity
- Extra large easy-to-read displays
- Simple operation... no thick instruction manual needed
- 2 year limited Warranty

List \$1898.00

ISI Price **\$1774.65**



#72634

ECONOMY SCALES #72595

- Push one button for all 4 wheel weights -- Push a second button for all partial %
- Heavy duty Red cables and silver AN connectors
- 15" CNC Machined low profile pads with carrying handles
- 2 line display shows 4 wheel weights and ANY %
- 1/10 % accuracy 1500 lbs per pad. capacity
- Includes molded carrying case for electronics, cables, battery and charger
- 2- year limited warranty

List \$1098.00

ISI Price **\$1026.65**



#72595



#72603

VISION BUDGET SCALES #72603

- Heavy duty Red cables and silver AN connectors
- Instant Recall Memory for 8 complete setups
- CNC Machined 15" low profile scale pads with handles and recessed connectors
- 1/10% accuracy and 1500 lbs per pad capacity.
- New advanced low power consumption electronics run on 2-9 volt batteries (included)

List \$1270.00

ISI Price **\$1187.45**

LIGHTWEIGHT ALUMINUM AIR TANK AND FILLER TIRE GAUGE

New design valve lets tank fill in 10 seconds or less. 7 gal. tank tops off 4 tires



#50465 Quick Fill Tire Gauge and Tank Assembly 0-15 psi
#50462 Quick Fill Tire Gauge and Tank Assembly 0-30 psi
#50460 Quick Fill Tire Gauge and Tank Assembly 0-60 psi
\$199.90 ea.

DUROMETER

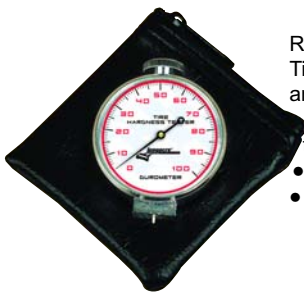

Racing Tire Hardness Tester
Tire Hardness changes as tires get older and even varies between new tires. Now you can keep track of exactly where your tires are. Track your tires with precision

- Reads from 0-100 points
- Comes with padded pouch

#50540 **\$59.95**

DIGITAL TIRE GAUGE



- Large 2 1/2" Gauge
- Air Pressure release button
- Pressure reading always active
- External gauge bumper
- 1.5 to 60 psi by .1 psi
- Hard case included

#50355 **\$139.95**

DELUXE TIRE PRESSURE GAUGES



- 2 1/2" Glow-In-The-Dark face for high accuracy and easy readability
- Hi Flow release buttons and swivel chucks
- Holds pressure until released
- Internal gauge damper for more accurate readings and longer life
- Ultra flexible 17" hose

#50402 0-60 by 1 lb. **\$44.95**
 #50422 0-30 by 1/2 lb. **\$44.95**
 #50452 0-15 by 1/4 lb. **\$44.95**

MEMORY TIRE PYROMETER

- Displays all 12 temps at once
- Stores 10 complete sets of temps w/ easy recall
- Built-in 4 car stopwatch w/ 75 lap Memory
- Tire temp averaging
- Built-in night light
- Take temps in any order
- Optional PC download and printer
- Low battery indicator
- Includes carrying case and probe



Memory pyrometer comes with case.

#50690 Memory Pyrometer **\$348.95**
 #50692 Memory Pyrometer w/ PC Download **\$399.75**

NON-MEMORY PYROMETER

- Accurate, super-fast response tire probe
- Large LCD Display
- Coil cord and carrying case

#50640 **\$148.95**
 #5074 Opt. 2000° Brake surface probe **\$94.95**



PIT IMPACT GUN

- True portability, no air hose to trip over
- High torque 24 volt - pops lug nuts off easily
- 1/2" drive, long lasting battery, fast charge



Impact gun with 2 batteries & Fast charger
 #68504 **\$259.95**

LATE MODEL CAR COVER

Cut specially to fit race cars - Keep your car cooler & cleaner between races.



- Heat reflective silver color
- Soft liner will not scratch paint
- Zippered window to get in and out
- Moisture resistant

#11150 Asphalt Late Model **\$179.95**
 #11152 Dirt Late Model **\$214.95**
 #11154 Open Wheel Modified **\$189.95**

CASTER/CAMBER GAUGES

8° +/- caster range, 6° +/- camber range
 Comes with foam lined protective carrying case
 Accurate to 1/4°



Caster/Camber Gauges w/ adapters & Carrying Case

LON-78100 . . Karting Camber Gauge **\$119.95 ea.**
 LON-78250 . . Gauge and Case Only - No Adapter **\$98.95 ea.**
 LON-78260 . . C/C Gauge w/ Mag Adapter **\$129.95 ea.**
 LON-78264 . . C/C Gauge w/ Wide 5 Adapter **\$128.95 ea.**
 LON-78290 . . Digital C/C Gauge w/ Mag Adaptor **\$189.95 ea.**

DIGITAL CASTER/CAMBER GAUGE

Here's a super accurate Digital Caster/Camber Gauge that reads to .1° camber and at a price any serious team can easily justify. (Caster is measured by bubble vial and reads from -4° to +12°.) It comes with our latest Super Magnetic adapter and a padded carrying case. As an additional benefit the AccuLevel™ digital readout can be removed and used separately as a digital angle finder for suspension, spoiler angles, and many other things.



Model #78290 **\$198.95**

ProFormer

SHEET METAL BRAKES

HEAVY DUTY BP-SERIES

Model	Bending Length	Capacity	Counter Weights	Depth of Box/Pan	Weight	Price
BP3620	3'	20 ga.	Optional	2-3/8"	220	\$620.00
BP3616	3'	16 ga.	1 Incl.	3-1/2"	295	\$780.00
BP4820	4'	20 ga.	Optional	2-3/8"	280	\$770.00
BP4816	4'	16 ga.	1 Incl.	3-1/2"	365	\$1,090.00
BP6020	5'	20 ga.	Optional	3-1/2"	850	\$2,120.00
BP6016	5'	16 ga.	2 Incl.	3-1/2"	940	\$2,420.00
BP7222	6'	22 ga.	Optional	3-1/2"	640	\$1,580.00
BP7220	6'	20 ga.	Optional	3-1/2"	980	\$2,300.00
BP7216	6'	16 ga.	2 Incl.	3-1/2"	1060	\$2,480.00

INDUSTRIAL CLASS U-SERIES

Model	Bending Length	Capacity	Counter Weights	Depth of Box/Pan	Weight	Price
U4-4816	4'1"	16 ga.	1 Incl.	4-1/2"	500	\$1,390.00
U4-4814	4'1"	14 ga.	1 Incl.	4-1/2"	720	\$1,960.00
U4-4812	4'1"	12 ga.	2 Incl.	4-1/2"	1280	\$3,200.00
U4-6016	5'1"	16 ga.	2 Incl.	4-1/2"	1470	\$3,500.00
U4-6012	5'1"	12 ga.	2 Incl.	4-1/2"	1730	\$4,300.00
U4-7216	6'1"	16 ga.	2 Incl.	4-1/2"	1520	\$3,800.00
U4-7214	6'1"	14 ga.	2 Incl.	4-1/2"	1750	\$4,100.00
U4-7212	6'1"	12 ga.	2 Incl.	4-1/2"	1900	\$4,400.00
U4-9716	8'1"	16 ga.	2 Incl.	4-1/2"	2320	\$5,400.00
U4-9714	8'1"	14 ga.	2 Incl.	4-1/2"	2490	\$5,900.00
U4-9712	8'1"	12 ga.	2 Incl.	4-1/2"	2780	\$6,200.00
U4-12116	10'1"	16 ga.	2 Incl.	4-1/2"	2890	\$7,500.00
U4-12114	10'1"	14 ga.	2 Incl.	4-1/2"	3010	\$7,850.00
U4-12112	10'1"	12 ga.	2 Incl.	4-1/2"	3470	\$8,200.00
U6-4820	4'1"	20 ga.	Optional	6"	700	\$1,860.00

INDUSTRIAL CLASS C-SERIES

Model	Bending Length	Capacity	Counter Weights	Depth of Box/Pan	Weight	Price
C6-4816	4'1"	16 ga.	2 Incl.	6"	960	\$2,750.00
C6-4814	4'1"	14 ga.	2 Incl.	6"	1030	\$3,360.00
C6-4812	4'1"	12 ga.	2 Incl.	6"	1590	\$4,600.00
C6-7216	6'1"	16 ga.	2 Incl.	6"	1870	\$5,100.00
C6-7212	6'1"	12 ga.	2 Incl.	6"	2260	\$5,800.00
C6-9712	8'1"	12 ga.	2 Incl.	6"	3170	\$8,000.00
C6-12116	10'1"	16 ga.	2 Incl.	6"	3330	\$8,500.00



Built to last and to be reliable in the real world: Clamp cams, vertical guide assemblies, clamp nose bar, entire clamp assembly, apron bushings, and apron leaf are replaceable.

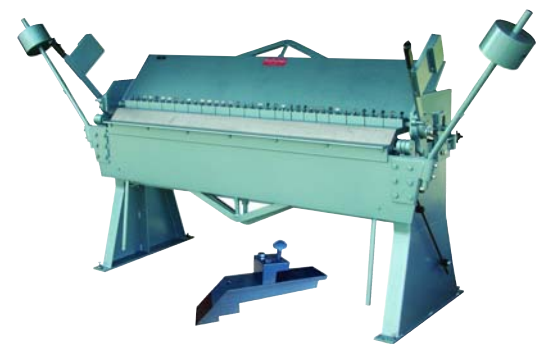

Rear Operated Back Gauge With usable depth of 48" you can bend sheet metal the same depth time and time again.

Add to price of any model: 3' & 4' \$350, 5' & 6' \$410, 8' & 10' \$480.

Bolt-On Radius Bar 1/16" to 1/2" radius: 3' or 4' \$90, 5' or 6' \$137, 8' or 10' \$220. Many other radius sizes are available-call for quotes.

NOTE: Using a bolt-on radius bar requires a Bolt-on Apron Angle if the radius is greater than 1/4" (1/2" diameter).

*Bolt on radius bars might not work above 20 ga. mild steel or .050 aluminum.

Magnetic Radius Bar These radius bars can be used at full rated capacity of the brake and hold themselves on without bolting. They are also suitable for cutting up into segments for use with finger brakes. 3' \$315, 4' \$368, 5' \$424, 6' \$473, 8' \$578, 10' \$683.

Bolt-On Apron Angle Included on all models except 3' to 6' 20 ga. For \$11 per foot you can add a bolt-on apron angle to your 3' or 6' 20 ga. brake. It will increase the full length capacity to 18 ga. This will be needed if using a bolt-on radius bar larger than 1/2" diameter on 3' or 6' 20 ga. models.

Counter Weight(s) are included on all 16-ga., 14-ga., & 12-ga. models and optional on all others.

For 20-ga. & 18-ga. 3' or 4' brakes and 22-ga. 6' \$50 each For 20-ga. & 18-ga. 5' or 6' Brakes \$80 each

Leg Kits For 3' or 4' 16-ga. or lighter brakes* (All other models are built-on legs) 55 lbs. \$86

*Exception: L & U 48" 16-ga. are available as floor models with welded on legs!! 110 lbs. \$110

HEAVY DUTY S-SERIES

Model	Bending Length	Capacity	Counter Weights	Depth of Box/Pan	Weight	Price
S3620	3'	20 ga.	Optional	1-1/4"	155	\$390.00
S3616	3'	16 ga.	1 Incl.	1-1/4"	255	\$620.00
S4018	3'4"	18 ga.	Optional	1-1/4"	140	\$390.00
S4820	4'	20 ga.	Optional	1-1/4"	240	\$660.00
S4816	4'	16 ga.	1 Incl.	1-1/4"	315	\$880.00
S6020	5'	20 ga.	Optional	2"	620	\$1,420.00
S6016	5'	16 ga.	2 Incl.	2"	870	\$1,900.00
S7222	6'	22 ga.	Optional	2"	415	\$930.00
S7220	6'	20 ga.	Optional	2"	740	\$1,460.00
S7216	6'	16 ga.	2 Incl.	2"	930	\$1,960.00
S9622	8'	22 ga.	2 Incl.	2"	1000	\$2,180.00



INDUSTRIAL CLASS L-SERIES

Model	Bending Length	Capacity	Counter Weights	Depth of Box/Pan	Weight	Price
L4816	4'1"	16 ga.	2 Incl.	2"	470	\$1,190.00
L4814	4'1"	14 ga.	2 Incl.	2"	670	\$1,610.00
L4812	4'1"	12 ga.	2 Incl.	2"	1090	\$2,780.00
L6014	5'1"	14 ga.	2 Incl.	2"	1330	\$2,560.00
L7216	6'1"	16 ga.	2 Incl.	2"	1420	\$2,650.00
L7214	6'1"	14 ga.	2 Incl.	2"	1570	\$3,030.00
L7212	6'1"	12 ga.	2 Incl.	2"	1790	\$3,540.00
L9720	8'1"	20 ga.	2 Incl.	2"	1750	\$3,290.00
L9718	8'1"	18 ga.	2 Incl.	2"	2040	\$3,460.00
L9716	8'1"	16 ga.	2 Incl.	2"	2140	\$3,670.00
L9714	8'1"	14 ga.	2 Incl.	2"	2270	\$4,000.00
L9712	8'1"	12 ga.	2 Incl.	2"	2400	\$4,620.00
L12120	10'1"	20 ga.	2 Incl.	2"	2260	\$4,210.00
L12118	10'1"	18 ga.	2 Incl.	2"	2380	\$4,540.00
L12116	10'1"	16 ga.	2 Incl.	2"	2640	\$5,520.00
L12114	10'1"	14 ga.	2 Incl.	2"	2760	\$5,800.00
L12112	10'1"	12 ga.	2 Incl.	2"	3120	\$6,400.00



HYDRAULIC ASSIST FOR L, U, & C MODELS

THE WAY to form 8' or 10' of 16 ga. or any length heavier gauge up to 10' of 12 ga. Includes foot switch that can be used from either end of the brake (or deduct \$100 for frame mounted switch). You can adjust the speed so that you will achieve a 90° bend in about 8 to 15 seconds.

\$3,500.00

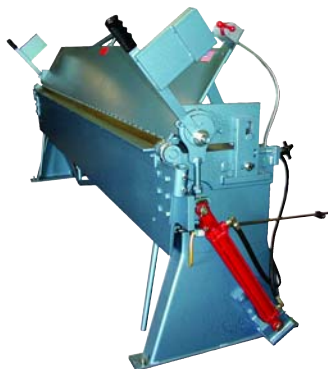

PROFORMER RADIUS BRAKES

#RB-7216 6 Foot 16 ga. Radius Brake*.....**\$1,790.00**

#RB-9620 8 Foot 20 ga. Radius Brake*.....**\$2,160.00**

#RB-12020 10 Foot 20 ga. Radius Brake**.....**\$2,800.00**

*6' & 8' Radius Brake comes with 5 radii: 4 radius tubes + 1 radius head.

Tubes are used for 1" radii and larger.

Four tubes included are as follows:

2" Tube for 1" Radius 3" Tube for 1-1/2" Radius
 2-1/2" Tube for 1-1/4" Radius 4" Tube for 2" Radius

**10 Foot Radius Brake comes with:

3" Tube for 1-1/2" Radius
 4" Tube for 2" Radius



Made In The USA



SHEET METAL BRAKES BENCH TOP MODELS

Simplicity of design allows these brakes to work in the most direct fashion. Easy to set up and operate. Body sections are welded steel plates with heavy truss rods and braces for longer life and greater strength. These brakes are standard with extension handles, counterweight, apron stop for repeat bends, and replaceable bushing at point of wear.

Model No.	Price	Bending Length	Gauge Capacity	Finger Width	Shipping Weight
S4816	\$1,070.00	48 1/4"	16	NA	470 lbs.
U4816	\$1,175.00	48 1/4"	16	2", 3", 4"	500 lbs.

STANDARD FLOOR MODELS

NATIONAL offers these hand brakes with a great deal of pride. A simple design, utmost strength with a long life of dependable service. Streamline design for fast, accurate bending even for the inexperienced workman. Heavy steel body construction with extra heavy tie rods for perfect alignment. Precision bearings on the apron assures you of a smooth operating brake. These brakes come with a full year warranty.

Model No.	Price	Bending Length	Gauge Capacity	Shipping Weight	Beam Adjustment
N4812	\$3,055.00	49"	12	1059 lbs.	1"
N7212	\$3,600.00	73"	12	1800 lbs.	1"
N9616	\$3,235.00	97"	16	1600 lbs.	1"
N9614	\$3,665.00	97"	14	1750 lbs.	1"
N12016	\$4,825.00	121"	16	2800 lbs.	1"
N12014	\$5,280.00	121"	14	3200 lbs.	1"



BOX AND PAN FLOOR MODELS

Four popular floor model box and pan brakes designed to be easy and simple to operate. Standard with 2", 3" and 4" finger widths, stop rods for repeat bends, two large counter weights, and precision bearings on the apron. All steel body construction with extra heavy tie rods for minimum deflection.



Prices FOB Factory

Model No.	Price	Bending Length	Gauge Capacity	Finger Width	Shipping Weight
U4812	\$3,125.00	49"	12	2", 3", 4"	1150 lbs.
U7216	\$3,875.00	73"	16	2", 3", 4"	1850 lbs.
U7212	\$4,310.00	73"	12	2", 3", 4"	2100 lbs.
U9616	\$4,785.00	97"	16	2", 3", 4"	2200 lbs.

30" 3 IN 1 COMBINATION OF SHEAR, BRAKE, & ROLL

Enco



Shear: Cuts full 30" width of 20 ga. mild steel

Press Brake: Sectional Fingers allows box and pan work up to 30"

Slip Roll: Uses 1 1/2" diameter rolls with wire-forming grooves.

Model #130-5610

\$368.95

Weight 340 lbs.

Take it to the race track for those emergency repairs. Perfect for testing sessions.

Not Recommended for everyday shop use.

Williams
LOWBUCK® TOOLS

PLATE BRAKE

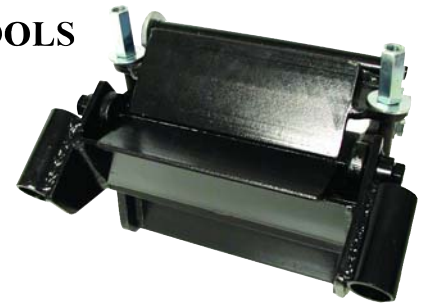

Bends Metal, mild steel or aluminum up to 1/8" x 6", or 1/4" x 2" without scarring it with a hammer. The compact rugged plate brake bolts to your workbench for operation. Comes assembled and painted. Handle not included.

\$210.00

RW Roper Whitney

PEXTO

Made In The USA

Roper Whitney's Connecticut brand sheet metal brakes are all steel welded construction. They feature bushings or pins at points of wear. Plastic handle grips are standard. Beam adjustment allows up to 1/8" setback from edge of bed.

RW STRAIGHT SHEET METAL BRAKES

Model	Bending Length	Capacity	Counter Weights	Depth of Box/Pan	Weight	Price
S422	4'-1/4"	22 ga.	N/A	N/A	210	\$635.00
816	8'1"	16 ga.	2 Incl.	1-5/8"	1640	\$3,760.00
1016	10'1"	16 ga.	2 Incl.	2-1/4"	2660	\$5,700.00
1018	10'1"	18 ga.	2 Incl.	1-5/8"	2200	\$4,600.00



RW BOX & PAN U-MODEL BRAKES

Model	Bending Length	Capacity	Counter Weights	Depth of Box/Pan	Weight	Price
U218	2'-1/4"	18 ga.	N/A	3"	155	\$830.00
U422	4'-1/4"	22 ga.	N/A	3"	280	\$880.00
U416	4'	16 ga.	1 Incl.	4"	495	\$1,460.00
U414	4'-1/4"	14 ga.	1 Incl.	6"	1400	\$3,700.00

LEG KIT

- Converts bench model brakes to floor model brakes
- Heavy wall square tubing
- Comfortable working height
- Powder coated

For 22 ga. brakes #U422LK **\$140.00**

For 16 ga. brakes #U416LK **\$150.00**

RW MAGNA BEND

Model	Descrip.	Capacity	Maximum Sheet Length	Weight	Price
MBB-4181	4 Ft./115V	18 ga.	48"	290	\$2,500.00

Other sizes available - call for details & pricing



Magnabend offers performance characteristics no conventional bending brake can match. The unique electromagnetic design of the keeper clamping system allows you to form many complex shapes not possible before. Plus, Magnabend can handle all regular shapes in light ferrous and nonferrous sheet metal (up to 4' wide, 18 ga.) in a simpler, less time consuming and efficient manner.

The rugged simple construction incorporating only one moving part assures low maintenance and versatility for all light duty forming requirements.

A wide variety of complex shapes can be formed with Magnabend. These include rolled edges up to 330°, partial length bends, closed shapes, unlimited depth for boxes and heavier material bends (up to 10 ga.) in shorter widths.

Design Features Assure Quality

Simplicity is evident in Magnabend's electromagnetic design which eliminates a conventional upper beam and more complex finger arrangements. Keepers (clamping members) are simply positioned over the workpiece and are clamped in place electromagnetically when the bending beam is raised. Keepers self-adjust for material thickness as the apron moves.

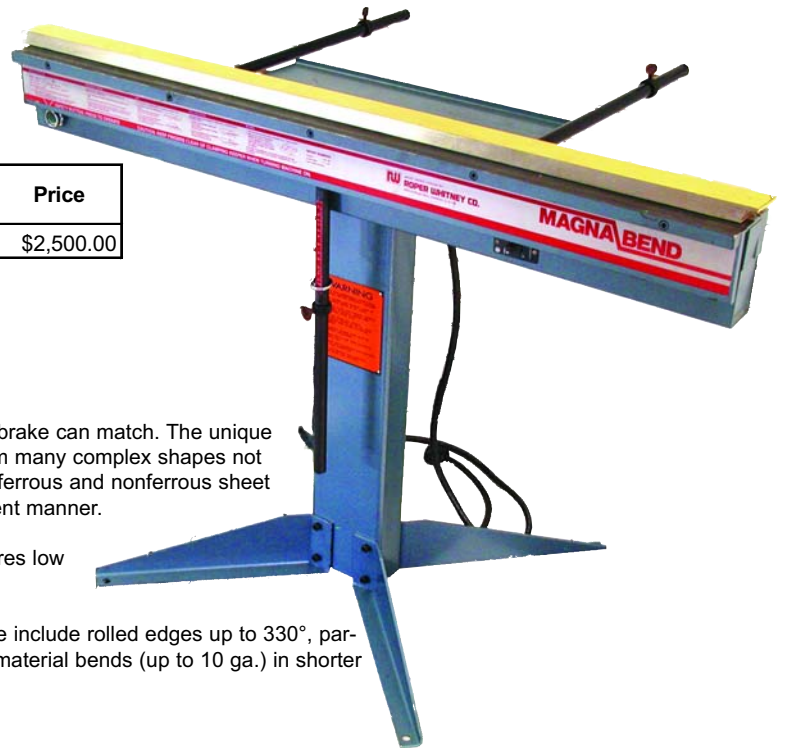



SHEET METAL SHEARS

FOOT SHEAR

52" 16 ga.

NATIONAL foot shears are designed for precise shearing up to 16 ga. mild steel. This shear is also recommended for shearing aluminum, plastic, copper, brass, and lead. All cast iron body with four cutting edge high carbon, high chromium blades, back gauges, front gauges, side gauges, spring actuated hold-down, clear plastic finger guard, front arm extensions, bottom treadle safety stop, and three year warranty on parts.



AIR SHEARS

52" 16 ga.

52" 12 ga.

NATIONAL offers two heavy duty all cast iron body air shears. These air shears are standard with four cutting edge carbon high chromium blades, front arm extensions, table gauges, back gauges, heavy duty foot switch, two air cylinders, and three year warranty on parts.

We recommend 100 PSI or more for ideal cutting pressure.

HYDRAULIC SHEARS

52" 16 ga.

52" 12 ga.

52" 10 ga.

NATIONAL heavy duty power shears are equipped with a fully integrated hydraulic unit. Complete with electrical hydraulic valve, pilot operated pressure relief valve, heavy duty foot switch that allows this unit to return to the top of the stroke when the operator removes his foot from the foot switch. Heavy duty double acting cylinders. Fully enclosed control panel. Includes three year warranty on parts.

The National shear is actuated by a portable shrouded electric foot switch attached to a long flexible cable so it may be positioned comfortably for the operator.



Extra heavy cast iron body with solid 4-edge high carbon, high chromium blades. Quick adjusting back gauge for direct reading with a positive lock standard with table gauges and front arm extensions.

Model No.	Price	Capacity	Strokes Per Minute	Cutting Length	Shipping Weight
N5216 (Foot Shear)	\$2,999.00	16 ga.	-	52"	935 lbs.
NA5216 (Air)	\$4,390.00	16 ga.	40	52"	1400 lbs.
NA5212 (Air)	\$6,960.00	12 ga.	40	52"	1600 lbs.
NH5216 (Hyd)	\$5,300.00	16 ga.	25	52"	1400 lbs.
NH5212 (Hyd)	\$8,510.00	12 ga.	25	52"	1600 lbs.
NH5210 (Hyd)	\$10,280.00	10 ga.	25	52"	1950 lbs.
NH4825 (Hyd)	\$16,025.00	1/4"	20	48"	5000 lbs.
NH7225 (Hyd)	\$20,350.00	1/4"	20	72"	6000 lbs.
NH12025 (Hyd)	\$29,150.00	1/4"	20	121"	11000 lbs.

Roper Whitney

PEXTO

FOOT SHEAR

SHEET METAL SHEARS

Roper Whitney Pexto foot squaring shears are the industry's most accurate. They are easy to operate and offer precise shearing, long life and dependability. Shatterproof transparent finger guards are among their safety features. All are provided with precise gauging and hold-downs for cutting accuracy.

- Maximum Rated Capacity: 16 ga. mild steel
- Built to machine tool standards
- Triple-action shearing

The No. 152 shears offer triple-action shearing which includes relief on both edges of both the fixed and moving blades. It eliminates blade-to-blade friction, provides "bite" to eliminate sheet movement under shearing stress and produces double penetration in the cutting action. All contribute to easier operation.

The No. G52 shear incorporates a gap-in-housing feature which permits slitting a sheet of any length (by successive cuts) up to 18 inches wide. Its gauging package is similar to the No. 152 shears, but also has an adjustable side slitting gauge. It may also be used for standard shearing of sheets up to 52" long. It includes a lever actuated holdout, finger guard and treadle stops.

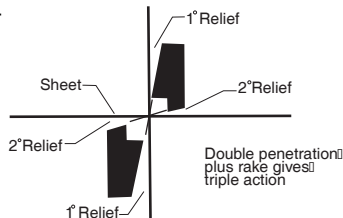

Price	\$2,870.00	\$12,300.00
Specifications	No. 152	No. G52
Maximum shearing length	52"	52"
Maximum back gauge range	25"	25"
Maximum front gauge range	30"	30"
Maximum slitting gauge range	-	18"
Floor space, gauges in position	66" x 76"	91" x 78"
Maximum rated capacity, mild steel	16 ga.	16 ga.

* For standard shearing.
Length unlimited when using as a slitter (up to 18" widths)

No. 152 Replacement blades \$415.00 ea. (2 required)

HYDRAULIC SHEAR

Compact, fully-integrated, hydraulically powered units. Ideal for many light gauge shearing applications. Equipped with big shear operating controls. Fast, smooth, oil-cushioned action. Both moving and fixed blades are shearing blades of Hi-Speed steel. One piece cast shear bed is recessed for easy sheet handling.

Standard equipment includes back, front, and side gauges, bevel gauges, front arms and transportation finger guard. Bed is machined for optional side extension squaring gauge.

Other Features include:

- Fully enclosed control panel, with magnetic starter, selector switch and relays
- Single or continuous stroke operation
- Heavy duty foot switch. If released anywhere in the stroke, crosshead returns to "up" position
- Pressure relief valve to prevent overloading
- Electric solenoid hydraulic valving for instantaneous response
- Dial stroke control - accessible adjustment with stroke length indicator
- Hydraulic power uniformly applied through double-acting cylinders

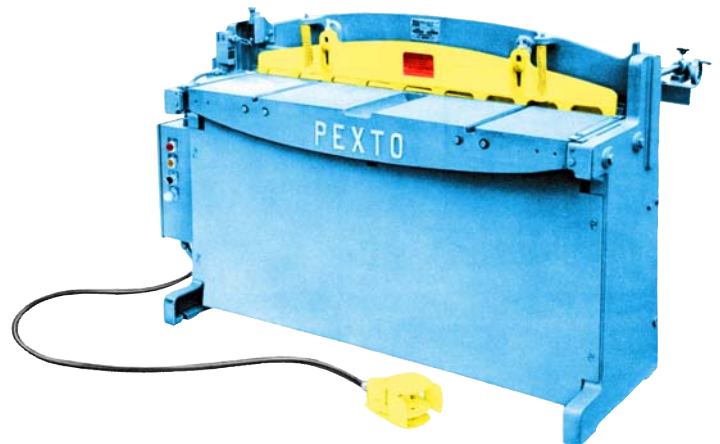

Price	\$6,171.00
Specifications	No. PH452
Maximum shearing length	52"
Maximum back gauge range	25"
Maximum front gauge range	37"
Floor space, gauges in position	66" x 76"
Maximum rated capacity, mild steel	16 ga.
Standard Motor	2hp
	1800 RPM
	3-phase

* Price Includes Front Support Arms, Front and Bevel Gauges

SLIP ROLLS

Roper Whitney PEXTO

	No. 383	No. 381	No. 0381	No. 390	No. 392	No. 416	No. 418
Price	\$760.00	\$875.00	\$1,070.00	\$3,885.00	\$3,940.00	\$4,150.00	\$4,022.00
Capacity mild steel (ga.)	20	22	24	16-18	20-22	16	18
Max. sheet length	24	36	42	36	48	36	48
Roll diameter (in.)	2	2	2	2 1/2	2 1/2	3	3
Gearing ratio	-----Direct Drive-----			2.4:1	2.4:1	4:1	4:1
Wiring grooves (in.)	3/16, 1/4, 5/16	3/16, 1/4, 5/16	3/16, 1/4, 5/16	1/4, 9/32, 5/16, 3/8	1/4, 9/32, 5/16, 3/8	3/8, 1/2, 5/8	3/8, 1/2, 5/8



Optional Floor Mount Stand



No. 383

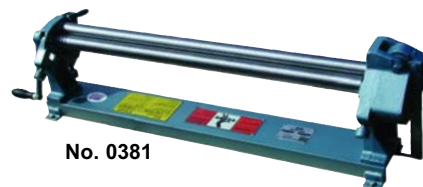

No. 0381

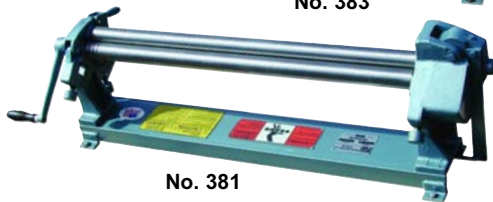

No. 381

Manually Operated Work rolls of precision turned and ground high carbon steel. 2", 2 1/2", and 3" diameter rolls with wiring grooves and fully enclosed gear housings. 2" & 2 1/2" dia. have two driven rolls with 3rd roll drive optional; 3" has three driven rolls. Two handles provided for 2 1/2" & 3" sizes only. Upper roll lifts for convenient removal of workpiece. Bench mounted, with welded steel cabinet stand available. The rear rolls of No. 416 and No. 418 are provided with three full length longitudinal grooves.

JET[®] MANUAL SLIP ROLLS

Model	SR-2024	SR-2236	SR-1650
Price	\$568.00	\$665.00	\$2,275.00
Capacity Mild	20 ga.	22 ga.	16 ga.
Max. Forming	24"	36"	50"
Number of Rolls	3	3	3
Diameter of Rolls	2"	2"	3"
Min. Forming	1"	1"	2"
Wire Grooves	3/16", 1/4", 5/16"	3/16", 1/4", 5/16"	1/4", 5/16", 3/8"



\$5400.00

Irvan-Smith, Inc. takes the Jet Model #SR-1650 and makes a custom 110" extended slip roll that is ideal for the NASCAR body hanger. This special slip roll lets you roll a one piece side for stock car bodies. One piece sides use less bondo, which makes the cars lighter and fewer seams means less work and saves time.

Enco MANUAL ROLL

Perfect for the small race team or fab shop.
Attention Late model racers! Roll out those aluminum fenders! Make them yourself and save money!

Model	130-4501	130-4511	130-5501
Price	\$398.95	\$448.95	\$694.95
Maximum Roll Length	24"	36"	50"
Capacity	20 Ga.	22 ga.	16 Ga.
Diameter of Rolls	2"	2"	3"
Minimum Radius	1"	1"	1.5"
Weight	225 lbs.	273 lbs.	570 lbs.



Optional Stand #130-5075 \$154.95

COLD SAWS AND HORIZONTAL/ VERTICAL BAND SAWS

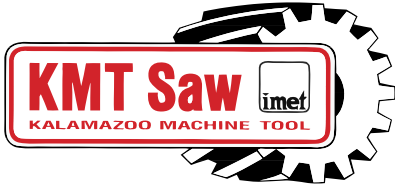

Kalamazoo Machine Tool - 10 reasons for choosing a circular cold saw:

- **Price** - Economical purchase price
- **Simple Operation** - Uncomplicated and very easy to understand and use
- **Maintenance** - Proper maintenance is simple, and very little is required
- **Size** - Compact and takes up very little room in your shop
- **Cost per cut** - Saw blades can be resharpened and retooled
- **Finish** - High quality surface finish with burr free cuts
- **Squareness of cut** - Saw blade is a very rigid tool, holding very accurate tolerances
- **Time of cut** - Circular saw cutting times are very fast
- **Miters and Angles** - Easy and accurate with minimum set up time
- **Versatility** - The above listed characteristics make these machines the most versatile in your shop

SPECIFICATIONS C315/C350:

Recommended Capacities:
 Round - 4.5"
 Square - 3.75"
 Rectangular - 3.75" x 5" wide

Spindle RPM - 30/60
 Blade Specifications - 14"
 Motor - 3.5 H.P.
 Net Weight - 616 lbs.

Standard Equipment:
 TEFC Motor
 Totally Enclosed Transmission
 24-Volt Control
 Machine Stand- (Except C250)
 HSS Sawblades
 All Safety Guards
 Operator Manual/ Parts List



Call For Pricing

14" CIRCULAR COLD SAW

For Cutting Steel, Stainless Steel and Non-Ferrous Metals

Enco

After you use a cold saw once, you'll never go back to an abrasive cut off saw again! **NO Sparks or Dust!**

- Heavy Duty
- Burr-Free Cutting
- Smooth, Fast, Accurate Cutting
- Double Clamp Vise
- Built-In Cooling System
- In-Feed Roller Support and Adjustable Stop

Specifications:

Main Drive Motor 3 HP 220/440V 3 PH
 Blade Speed 20 RPM
 Head Swivel L 45° R 45°
 Coolant Pump Motor 1/8 HP
 Max. Clamping Capacity 5-7/8"
 Blade Size Required 14" x 3/32"
 Machine Size 29 1/2" x 35 1/2" x 59"
 Weight (Approx) 740 lbs.



Model #422-3687 Circular Cold Saw **\$3988.95**

Circular Saw Blades

#371-2140 14" x 3/32" x 158" Non Ferrous for 131-2014 **\$161.45** 3.53 lbs.
 #371-2145 14" x 3/32" x 158" Ferrous For 131-2014 **\$161.45** 4.50 lbs.

Enco

HEAVY DUTY COMBINATION HORIZONTAL/VERTICAL BAND SAW

Horizontal Capacity (Round) 5"
 Horizontal Capacity (Rectangular) 5"x6"
 Throat Depth 4 1/8"
 Work Table Size 6 1/2" x 10"
 Vise Tilts 45°
 Blade Size 1/2" x .025 x 64 1/2"
 Speeds (SFPM) 80, 120, 200
 Motor 1/3 HP, 1720 RPM
 Height, Vertical 54 1/4"
 Height Horizontal 38"
 Length 38"
 Width 12"
 Weight 125 lbs.

Model #505-6840 **\$228.95**



**2 Machines-
In-One. Instant
Change To
Vertical Cutting**



MFG. COMPANY, INC.
MOBILE MITRE BAND
SAWS



Bimetal Matrix Blades for Ellis Mobile Mitre Band Saws					
Model	Price	Length	Width	Thickness	Number of teeth per inch
1100	\$22.50	8' 0"	1/2"	0.025	6/10 VT, 8/12 VT, 10/14 VT*
1200	\$30.00	8' 6"	5/8"	0.032	5/8 VT*, 6/10 VT*, 10/14 VT*
1500	\$32.50	9' 6"	3/4"	0.032	4/6 VT, 5/7 VT*, 8/12 VT, 10/14 VT*
1600	\$35.00	10' 0"	1"	0.035	2/3VT, 3/4 VT, 4/6 VT, 5/7 VT, 6/10 VT, 8/12 VT, 10/14 VT*
1800	\$40.00	11' 0"			
2000	\$45.00	12' 0"			

* The general purpose blade for each width is emphasized.

Specifications	Model 1100	Model 1200	Model 1500
	\$2,595.00	\$2,695.00	\$2,795.00
Capacity	8 3/4" Round at 90° 10" flat at 90° 6 1/2" round at 45° 6 1/2" flat at 45°	8 3/4" Round at 90° 10" flat at 90° 6 1/2" round at 45° 6 1/2" flat at 45°	10" Round at 90° 11" flat at 90° 6 7/8" round at 45° 7 1/4" flat at 45°
Blade Speeds	70-135-250 FPM	70-135-250 FPM	70-135-250 FPM
Blade Size	8'0" x 1/2" x 0.025	8'6" x 5/8" x 0.032	9'6" x 3/4" x 0.032
Head Pressure	Hydraulic Cylinder	Hydraulic Cylinder	Hydraulic Cylinder
Vise	Quick Adjusting	Quick Adjusting - Deluxe	Quick Adjusting - Deluxe
Shut-off	Automatic	Automatic	Automatic
Motor	1/2 HP, 110 V, 60 hz, 1 PH	3/4 HP, 110 V, 60 hz, 1 PH	3/4 HP, 110 V, 60 hz, 1 PH
Portable	10" wheels standard	10" wheels standard	10" wheels standard
Shipping weight	370 lbs.	385 lbs.	435 lbs.
Size	Table Height - 26 1/2" Length - 50" Width - 23" Height - 44"	Table Height - 26 1/2" Length - 50" Width - 23" Height - 44"	Table Height - 27 1/4" Length - 55 3/4" Width - 24 3/4" Height - 45 1/2"
Sealed Oil Bath Worm Gear	Standard	Standard	Standard
Removable Chip Tray	Standard	Standard	Standard
Construction	Heavy Steel, welded and machined for accuracy and durability; 14 sealed precision ball bearings	Heavy Steel, welded and machined for accuracy and durability; 14 sealed precision ball bearings	Heavy Steel, welded and machined for accuracy and durability; 14 sealed precision ball bearings
Air System (Cleans and cools blade) \$200.00	Optional	Optional	Optional
10" x 16" Vertical Table with blade guard \$50.00	Optional	Optional	Optional
Optional Stock stand - \$50.00	Stock stand w/ micro adjustable gauge. \$175.00	Stock stand w/ micro adjustable gauge. \$175.00	Stock stand w/ micro adjustable gauge. \$175.00
Single Stand - Tripod	Optional \$150.00	Optional \$150.00	Optional \$150.00

Features

- Head Moves Left or Right For Angle Cutting
- Stock Remains In One Position For All Cuts
- One Step Conversion from Horizontal to Vertical Band Saw
- Built In Protractor for Fast Accurate Selection Of Angles

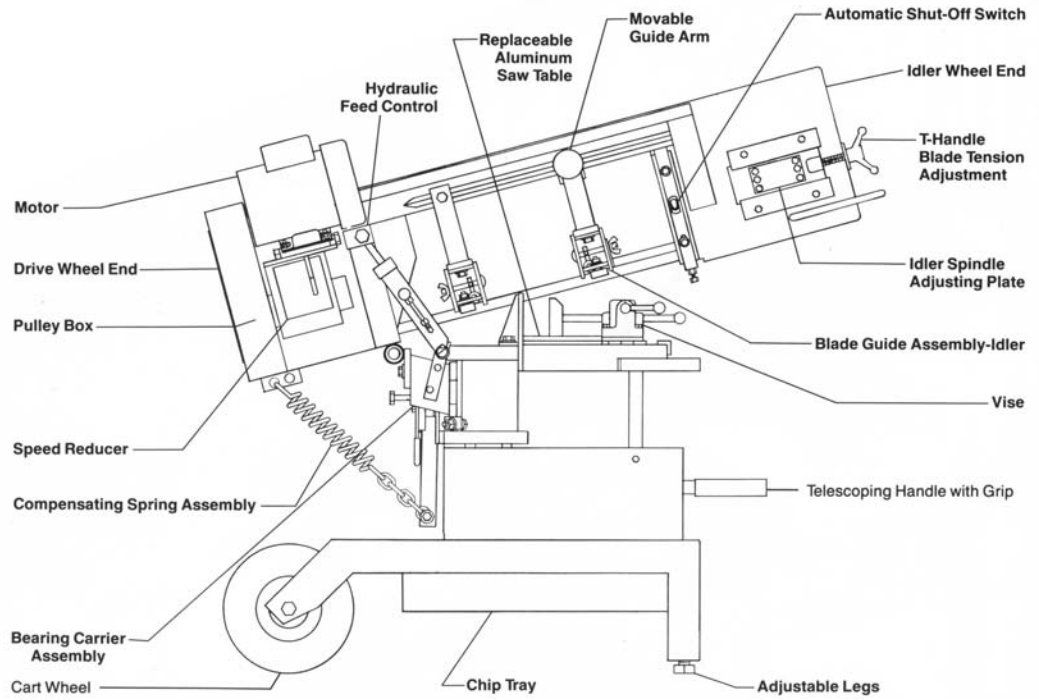

Specifications	Model 1600	Model 1800	Model 2000
	\$2,850.00	\$3,295.00	\$4,295.00
Capacity	10" Round at 90° 11" flat at 90° 6 7/8" round at 45° 7 1/4" flat at 45°	11" Round at 90° 14" flat at 90° 9" round at 45° 9.5" flat at 45°	11" Round at 90° 17" flat at 90° 11" round at 45° 11" flat at 45°
Blade Speeds	70-135-250 FPM	70-135-250 FPM	70-135-250 FPM
Blade Size	10' x 1" x .035	11' x 1" x .035	12' x 1" x .035
Head Pressure	Hydraulic Cylinder	Hydraulic Cylinder	Hydraulic Cylinder
Vise	Quick Adjusting	Quick Adjusting	Quick Adjusting
Shut-off	Automatic	Automatic	Automatic
Motor	1 HP, 110 V, 60 HZ, 1 PH	1 HP, 220 V, 1 PH	1 1/2 HP, 220 V, 1 PH
Portable	10" wheels standard	Not Portable	Not Portable
Shipping weight	475 lbs.	550 lbs.	800 lbs.
Size	Table Height - 27 1/2" Length - 59 1/4" Width - 24 3/4" Height - 47"	Table Height - 28" Length - 64" Width - 29" Height - 47"	Table Height - 28 1/8" Length - 72" Width - 34 1/4" Height - 47"
Sealed Oil Bath Worm Gear	Standard	Standard	Standard
Removable Chip Tray	Standard	Standard	Standard
Construction	Heavy Steel, welded and machined for accuracy and durability; 14 sealed precision ball bearings	Heavy Steel, welded and machined for accuracy and durability; 14 sealed precision ball bearings	Heavy Steel, welded and machined for accuracy and durability; 14 sealed precision ball bearings
Air System (Cleans and cools blade) \$200.00	Optional	Optional	Optional
10" x 16" Vertical Table with blade guard \$50.00	Optional	Optional	Optional
Optional Stock stand - \$50.00	Stock stand w/ micro adjustable gauge. and 2 rollers \$175.00	Stock stand w/ micro adjustable gauge. and 2 rollers \$175.00	Stock stand w/ micro adjustable gauge. and 2 rollers \$175.00 5' Long - 4 roller stand - \$350.00
Single Stand	Optional \$150.00	Optional \$150.00	Optional \$150.00



Enco VERTICAL BAND SAWS

- Will cut steel, aluminum alloys, cast iron, brass, even plastic or plexiglass
- Both models come complete with large capacity welder, blade cutter, blade grinder and work lamp
- 0.025" blade thickness
- Table inclination 15° front and back, 15° right and left
- Infinitely variable speed

Model #135-1545
\$2,443.95

Model #135-1551
\$2,649.95

Model	135-1545	135-1551
Vertical Bandsaw	14 3/4"	18"
Motor & electrical	1 HP, 220V, 1 PH	1 HP, 220V, 3 PH
Speeds SFPM	65 to 265	80 to 320
Capacity Thickness	9 1/4" Max	10" Max
Capacity Width	14 3/4" Max	18" Max
Table Size	19 3/4" x 19 3/4"	23 1/2" x 19 1/2"
Blade length	113"	136"
Blade width	3/8"	3/32" to 5/8"
Blade thickness	0.025"	0.025"
Height Floor to Table	39 1/4"	38 1/4"
Overall Height	68"	79"
Welder	2.0 KVA	2.4 KVA
Approx. Wt.	760 lbs.	770 lbs.



GROB VERTICAL BAND SAWS

Call For Pricing



4V-18

Grob 4V-18 Standard Equipment

- 3 hp. 230/460 Volt Motor
- Infinitely Variable Speed 40-5000 FPM
- Speed Indicator
- Balanced Cast Aluminum Saw Pulleys, Ball Bearing Mounted, Oil Resistant Rubber Facing
- Heavy Cast Iron Table - Tilt 45° down right, Tilt 5° down left
- 3/8" - 1/2" Single Pc. Saw Guide



4V-24

Grob 4V-24 Standard Equipment

- 3 hp. 230/460 Volt Motor
- Infinitely Variable Speed 40-5000 FPM
- Speed Indicator
- Balanced Cast Aluminum Saw Pulleys, Ball Bearing Mounted, Oil Resistant Rubber Facing
- Heavy Cast Iron Table - Tilt 45° down right, Tilt 5° down left
- 3/8" - 1/2" Single Pc. Saw Guide

It is GROB's ongoing mission to be the standard by which all industrial bandsaws are measured. Their basic saw designs have kept pace with changing technologies. They have never lost sight that sound sawing principles are what our customers demand. GROB's current lineup meets and exceeds those demands by providing a range of products that match any metalcutting application. GROB saws are designed to deliver dependable operation year after year.

COMBO DISC & BELT SANDER/GRINDER



Made In The USA

20" DISC SANDER/GRINDER



Specifications

- Used for metal, wood, fiberglass and plastic
- Powered by BALDOR motor
- Miter gage standard
- Disc size = 12"
- Disc speed = 1960 rpm
- Disc table size = 9" x 16.375"
- Disc table tilt 20° up/45° down
- Belt size = 6" x 48"
- Belt Speed = 2850 SFM
- Belt table size = 7.25" x 14.75"
- Belt table tilt 20° up/45° down

#DB301 - 115V 1 PH 1.5HP - **\$1365.00**
#DB302 - 220V 1 PH 2.0HP - **\$1365.00**

Specifications

- Used for metal, wood, fiberglass and plastic
- Equipped with a Dayton "On-Off" reversing switch
- Powered by BALDOR motor
- Miter gage standard
- Disc size = 20"
- Bolt-down base
- Working table = 27.25" x 15"
- Working height = 37.5"
- Direct motor drive
- Table can be tilted 35° upward and 45° downward
- Rack mechanism for raising & lowering table 32" x 30" floor space required
- Machine weight (approx.) = 310 lbs.



#DG201 - 115V 1 PH 1.5HP - 1725 RPM **\$1695.00**
#DG203 - 230V 3PH 2.0HP - 1740 RPM **\$1665.00**
#DG202 - 230V 1PH 1.5HP - 1725 RPM **\$1695.00**
#DG204 - 460V 3PH 2.0HP - 1740 RPM **\$1695.00**

SANDERS AND GRINDERS

We stock replacement belts and discs for ALL models

BURR KING®

Model 760 Abrasive Belt Grinder is our most versatile machine. It offers contact, backup platen, worktable and loose belt grinding at 8000 S.F.P.M.



Model	Description	Price
760-MC150A	1 1/2 HP Motor 115/230V 1 phase	\$1995.00 ea.
760-MC150B	1 1/2 HP Motor 230/460V 3 phase*	\$2510.00 ea.
760-MC200B	2 HP Motor 230/460V 3 phase*	\$2567.00 ea.
760-MC300B	3 HP Motor 230/460V 3 phase*	\$2658.00 ea.
760-VARI-SPD	2 HP Motor 220V 1 phase	\$3017.00 ea.
BK-746A	PEDESTAL STAND	\$293.00 ea.
DS-7	DUST SCOOP FOR 760	\$183.00 ea.

*Note: Cord and Sw itch not included on all 3 phase models
Magnetic sw itch available on all models

BURR KING®

Model 960-250 features movement from vertical to horizontal position with standard 2 1/2" X 60" belt, recommended for contact wheel and platen grinding. Model 960-400 features a 4" x 60" belt. These units are available from 1 1/2 HP to 3 HP motors.



Model	Description	Price
960-250-Vari-Spd	1 1/2 HP Motor 220V 1 phase	\$2732.00 ea.
960-250-MC150A	1 1/2 HP Motor 115/230V 1 phase	\$2035.00 ea.
960-250-MC150B	1 1/2 HP Motor 230/460V 3 phase*	\$2549.00 ea.
960-250-MC200B	2 HP Motor 230/460V 3 phase*	\$2607.00 ea.
960-250-MC300B	3 HP Motor 230/460V 3 phase*	\$2696.00 ea.
BK-746	PEDESTAL STAND	\$279.00 ea.

*Note: Cord and Switch not included on all 3 phase models
Magnetic switch available on all models



HORIZONTAL BELT GRINDER

Features:

- Reduces Grinding Time
- Dependable and safe
- Low Noise Level
- Quick Change Belt



Price	\$1,195.00
Model No.	6000
Belt Dimension	2 1/2" x 60"
Belt Grit	36 to 220
Belt Speed	5000 SFM
Platen Size	2" x 12 1/2"
Shipping Dimensions	Width - 24"
	Length 30"
	Height - 48"
Shipping Weight	185 Lbs
Motor	1 HP Special Duty 3450 RPM, 60 Hz 110/208 V, 230 V
Contact Wheel	Precision Balanced 6" Diameter, 2 1/2" Wide 70 Duro, Serrated
Belt Grits	36, 50, 60, 80, 100, 120, 180, 220
Optional	Work rest, safety shield, and adjustable dust chute



BELT/DISC GRINDER

Our most versatile grinder! The Jet Model JSG-6DC Belt/Disc grinder is probably the most used piece of equipment in any metal fabrication shop. The tiltable work surfaces allow you to grind exact angles and bevels. A lateral slot is machined into each table for use with the included protractor slider. If you have only one piece of machinery in your shop, this is the one to have.



Price	\$913.00
Model No.	JSG-6DC
Belt Dimension	6" x 48"
Disc Diameter	12"
Belt Speed	2500 SFM
Belt Table Tilt (Down, Up)	45°, 20°
Disc Table Tilt	45°, 25°
Shipping Weight	210 lbs.
Motor	1 1/2 HP 1 phase 115/230V, Prew ired 115V
Optional Stand JSG-6SA	\$188.00

ABRASIVE BELTS, DISCS, BAND SAW BLADES AND ACCESSORIES



SANDING BELTS

- Belt - 6" x 48"40 Grit\$11.00 ea.
- Belt - 2 1/2" x 60"36 Grit\$7.50 ea.
- Belt - 2 1/2" x 60"50 Grit\$7.50 ea.
- Belt - 2 1/2" x 60"80 Grit\$7.50 ea.

SANDING DISCS

- Sanding Disc 12" 40 Grit\$6.50 ea.

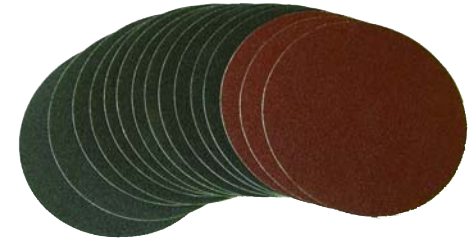

BAND SAW BLADES



COLD SAW BLADES

Enco 14" Circular Cold Saw Blades (Model 131-2014)			
Model	Size	Type	Price
371-2140	14"	Non Ferrous	\$161.45
371-2145	14"	Ferrous	\$161.45



Bimetal Matrix Blades for Ellis Mobile Mitre Band Saws					
Model	Price	Length	Width	Thickness	Number of teeth per inch
1100	\$23.75	8' 0"	1/2"	0.025	6/10VT, 8/12VT, 10/14VT*
1200	\$31.50	8' 6"	5/8"	0.032	5/8VT*, 6/10VT*, 10/14VT*
1500	\$34.25	9' 6"	3/4"	0.032	4/6VT, 5/7VT*, 8/12VT, 10/14VT*
1600	\$36.75	10' 0"	1"	0.035	2/3VT, 3/4VT, 4/6VT, 5/7VT, 6/10VT, 8/12VT, 10/14 VT*
1800	\$42.00	11' 0"			
2000	\$47.25	12' 0"			

* Most Common

Bimetal Matrix Blades for Enco Heavy Duty Combination Horiz/Vert Band Saws (Model 137-3150)				
Model	Length	Width	teeth per inch	Price
SB-137-3150	64 1/2"	1/2"	10/14VT	\$20.00

Bimetal Matrix Blades for Enco Vertical Band Saws (Model 135-1545)				
Model	Length	Width	teeth per inch	Price
SB-135-1545	113"	3/8"	10/14VT	\$35.00

ORDER ONLINE TODAY AT
[HTTP://WWW.IRVANSMITH.COM](http://www.IrvanSmith.com)

MOST ITEMS ARE IN STOCK AND READY TO SHIP.

ALSO GO TO OUR WEBSITE FOR INSTRUCTIONS, TIPS AND REPLACEMENT PARTS.

INGERSOLL-RAND® AIR COMPRESSORS

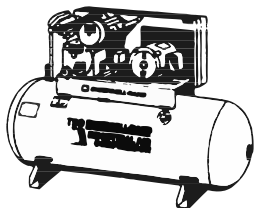

Irvan-Smith, Inc. is an Authorized Ingersoll-Rand Distributor.
 Call 1-800-221-7223 for your air compressor needs.

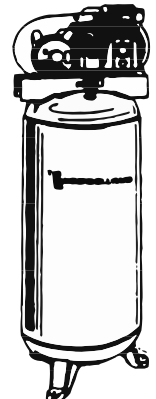



GLASS BEAD BLAST CABINETS

BLAST-IT-ALL blasting cabinets feature high-tech and innovative designs for cleaning, finishing and peening for complete surface preparations. They are engineered for operator comfort and efficiency, and are cost effective by decreasing production costs and increasing production rates. BLAST-IT-ALL cabinets are constructed of the highest quality materials with large, double-walled doors for a quieter working area. Included in these systems are a moisture separator, pressure regulator, gauge, and blow off gun. Its efficient reclaim system cleans and separates media for reuse. BLAST-IT-ALL cabinets also meet OSHA and CSA safety and noise requirements.

LITTLE BLASTER

Part Number	Description	Price
LB4024	40" W X 24" D X 24" H	\$1450.00 ea.
LB4024SP	40" W X 24" D X 24" H (Steel Shot Peener)	\$3800.00 ea.
LB42240S	42" W X 24" D X 24" H (Oyster Shell Opening)	\$1550.00 ea.
LB4824	48" W X 24" D X 24" H	\$1650.00 ea.

* Above models come with dust collectors
 * Optional reclaimers available.



BLAST-IT-ALL

Part Number	Description	Price
3636-7	36" W X 36" D X 40" H	\$4400.00 ea.
4426-7	44" W X 26" D X 32" H	\$4100.00 ea.
4836-7	48" W X 36" D X 34" H	\$4800.00 ea.
6048-7	60" W X 48" D X 42" H	\$5100.00 ea.

The above models come with 700 CFM reclaimers and dust bag
 Optional industrial type dust collectors available.

NOTE: We offer a full line of Blast-It-All Cabinets and parts. Plastic media paint stripping rooms available. If you have a specific need or don't quite see what you want, give us a call, we'll be glad to help.

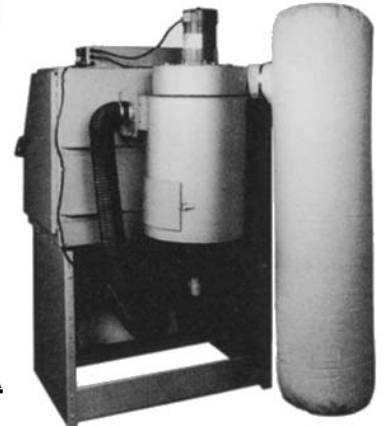

Media Reclaimer: An efficient reclaimer is not only designed to draw the media from the cabinet but also to remove the contaminants, dust, and fines from the media so that it can be efficiently reused. All spent media and contaminants are pneumatically pulled tangentially into the cyclone and they centrifugally separate the reusable media from the dust and foreign materials. The heavy contaminants are separated with a filter screen prior to collecting the reusable media into the storage section. The fine dust is pulled from the center of the cyclone separator into the dust collector. BLAST-IT-ALL media reclaimers are adjustable so that fine, medium or coarse media/abrasives can be used.

REPLACEMENT GLOVES



Replace those blaster gloves with holes in them.
8"x30" Replacement Gloves
 #22-077 Left Glove
 #22-078 Right Glove
\$14.00 ea.

GLASS BEAD MEDIA



Media: Most any media/abrasives can be used in BLAST-IT-ALL cabinets depending on the applications and/or options and accessories chosen. Different abrasive would be selected for cleaning, stripping, finishing, deburring, peening, shot-blasting, stress relieving, or sealing porosity.
50lb. Bags

Part Number	Description	Price
BLA-G-10	FINE GLASS BEAD	\$40.00 ea.
BLA-G-4	X-COARSE GLASS BEAD	\$40.00 ea.
BLA-G-6	COARSE GLASS BEAD	\$40.00 ea.
BLA-G-8	MEDIUM GLASS BEAD	\$40.00 ea.

WILTON[®]

WILTON MACHINERY

VERTICAL BAND SAWS

Wilton's heavy duty vertical band saws are a must when the job calls for contour sawing, beveling, slicing, ripping, or stack cutting.

- Two sizes to choose from
8020 - 20" vertical band saw
8014 - 14" vertical band saw
- Adjustable work lamp
- Built-in chip blower
- Chip Tray
- Blade speed and pitch selector
- Adjustable carbide blade guides
- Rip fence
- Optional blade welder available (Model 8000 and 8002)

COMBINATION BELT AND DISC FINISHING MACHINES

- 6" x 48" belt 2850 SPFM and 12" abrasive disc (1960 RPM)
- Cast iron head and table
- Deluxe mitre gauge
- Belt Operates at any angle
- Fully machined balanced disc runs vibration free
- Table tilts to 45° out to 20°
- Heavy duty steel one piece stand



Model 4200A

20" DISC SANDER

- Deburring, chamfering or grinding metal, wood, fiberglass and plastic
- Mitre gauge and LVP switch standard
- Extra large tilting table raises and lowers easily with a rack and gear mechanism. Table locks securely in any position.
- 3HP, 1725 RPM, 220/440V



Model 4421



Model 8020



Model 8014

TRADESMAN DRILL PRESSES

Standard Features

- Hinged metal belt and pulley cover
- Quick adjustment motor mount for rapid changing of spindle speeds
- Front mounted push button start/stop button
- Positive locking depth stop
- Spindle is supported by high quality ball bearings
- Drill chuck and arbor standard



Bench Model 2530 - 12 speed

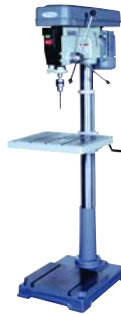

Floor Model 2550 - 12 speed



Floor Model 2500 - 12 speed

VARIABLE SPEED DRILL PRESSES

Standard Features

- LED spindle RPM readout
- 0-1/2" Key chuck and arbor standard
- 6" spindle stroke
- Rack and pinion table riser
- Variable speed drive
- Heavy duty cast iron construction
- Large cast iron T-slotted production table
- Positive depth stop



Model A5816



Model A5836

ROLL-IN SAW

"THE ORIGINAL"

NEW!



Roll-In Saw built its reputation on the versatility and durability of this terrific bandsaw – the EF1459, a.k.a, "The Original." This was the first saw in America to use a patented gravity-feed system that saves time and energy.

The EF1459 is actually a horizontal bandsaw on a vertical frame. An all-purpose band saw, it handles all metals, plastics, and woods in a wide variety of cuts. It is a fast, accurate cut-off machine that is perfect for notching, slotting, and slotting. A reliable addition to your shop floor, this bandsaw doubles as a contour, profile, and rip saw.

Model EF1459
\$4195.00

- Capacity Under Guides 14 1/2"
- Throat 8 3/4"
- Blade Travel 9" Blade travel into work
- Blade Size 3/4"Width x 8/12T x 10'Length .035 thick (bi-metal)
- Blade Guards Covers 4 step pulleys and blade
- Guide Rollers for Blade Width 1/4", 3/8", 1/2", 5/8" and 3/4"
- Blade Speeds 70, 140, 270 and 525 fpm
- Table Precision ground, cast iron table, 18 1/2" x 30"
- Table Height 30" from floor
- Wheels Cast iron, 14" x 1 1/8"
- Motor 1 HP, 110/220V, 60-cycle single-phase; 1 HP 220/440V, 60 cycle 3-phase
- Dimensions 30"Width x 66"Height x 40"Length
- Shipping Weight 585 lbs.

DRILL PRESSES

Enco FLOOR DRILL PRESSES

Features:

- Table tilts 45° both sides of center
- Rack and pinion table adjustment
- Closed hinge belt guard
- Graduated spindle travel stop



Specifications	Floor Model Specifications			
	Model 308-0056	Model 308-0057	Model 308-0058	Model 308-0059
Price	\$267.95	\$329.95	\$332.95	\$362.95
Swing	13"	17"	13.75"	17"
Drilling Cap.	5/8	3/4	5/8	3/4
Spindle Taper	MT2	2 MT	2 MT	2 MT
Quill Travel	3 1/8	3 1/8	3 1/8	3 1/8
Chuck Capacity	5/8	5/8	5/8	5/8
No. Of Speeds	16 (250-3000)	16 (240-2900)	16 (210-3600)	16 (240-2900)
Motor & Elec.	1/2 hp 115/230v, 1PH	1/2 hp 115/230v, 1PH	1/2 hp 115/230v, 1PH	1/2 hp 115/230v, 1PH
Overall Height	39 3/8	42	62-1/2	64
Table Size	11 7/16 D	11X11	9X9	11X11
Table T-Slots	1/2	1/2	1/2	1/2
Table Tilt	45 DEG	45 DEG	45 DEG	45 DEG
Column Dia.	2 7/8	3 1/8	2 7/8	3 1/8
Base Size	17 5/16X9 7/8	11X18	17-3/4 X 10 1/2	18-1/4X10-5/8
Approx. Weight	89.1 LBS	149.6	121	172

JET FLOOR DRILL PRESSES



- Hinged metal belt and pulley cover couples with quick adjustment motor mount to allow rapid changing of spindle speeds
- Rotating 45° tilting crank operated work table with quick release clamp
- On/Off switch located on front of drill press head
- A 1/2" diameter external positive depth stop with three nut locking feature for quick adjustment
- Adjustable tension spindle return spring
- Spindle is supported by high quality ball bearings
- Built-in work lamp on all models, bulb not included
- Drill chuck and key included

Model	JDP-20MF
Price	\$1,125.00
Swing In:	20 1/2"
Drilling Capacity	1"
Chuck Size	3/4"
Spindle Travel:	4 5/8"
Spindle Distance to Base	46 3/4"
Spindle Distance to Table	29 1/8"
Table Size	18 5/8" x 16 1/8"
Spindle Taper	MT-3
Column Diameter	3 3/8"
Number of Spindle Speeds	12
Range of Spindle Speeds	150-4200
Base Size	13 5/8" x 22 3/8"
Motor	1 1/2 HP 1 phase 115/230V prewired 115V
Approx. Shipping Weight	301 lbs.



ELLIS 9500 INFINITELY VARIABLE 20" DRILL PRESS

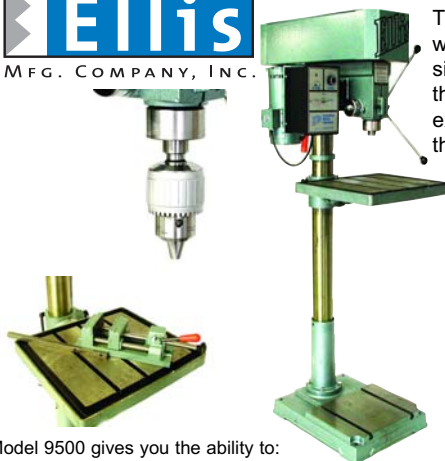

These drill presses are the overwhelming choice of most professional racing teams. They provide the speed and control of an expensive milling machine with the ease of use of a low cost drill press.

Model 9400 Drill Press
\$2395.00

Model 9500 Drill Press
\$2895.00

Optional Ball Bearing Chuck/Arbor
1/8" to 5/8" - \$100.00
1/8" - 3/4" - \$125.00
Optional 4 5/8" Vise - \$150.00

Model 9500 gives you the ability to:

- Vary Your speed from 0 to 1200 RPM
- Adjust speeds while operating in material
- High torque at low RPM speeds
- Instantaneous reversing for tapping
- Tapping head is not needed
- Machine tap goes into ball bearing chuck
- Can tap either left of right handed threads
- Drill head and table rotate 360° around column
- T-slotted production table tilts and rotates
- Smooth operating table riser
- Fully enclosed spindle
- Quill lock and depth control
- 1 1/2 HP AC Motor
- 110/220V 1 phase

Model	9400	9500
Spindle Speeds	0-1200 RPM	0-1200 RPM
Drills to center	18 1/8"	20"
Drilling capacity	Steel - 1 1/16" Cast Iron - 1 1/4"	Steel - 1 1/16" Cast Iron - 1 1/4"
Tapping	3/4"	3/4"
Morse Taper	No. 3	No. 3
Quill Diameter	3"	2 1/8"
Column	4"	4"
Spindle Travel	5 3/8"	5 1/8"
Spindle to table	27 1/4"	26 1/2"
Shipping weight	675 lbs	500 lbs
Table	Production type T-15 7/8" x 17 7/8" 2 slots for 1/2" t-bolts Ground working Coolant trough	Production type T-16 5/8" x 18 5/8" 2 slots for 1/2" t-bolts Ground working Coolant trough
Base	T-slotted 16 3/8" x 26 5/8" 2 slots for 1/2" t-bolts Ground working	T-slotted 18" x 25 1/2" 2 slots for 1/2" t-bolts Ground working
Size	69 1/2" Width - 20" Depth - 29"	Height - 70 1/2" Width - 20" Depth - 34 1/4"

VERTICAL MILLING MACHINE

with 49" Table

- 1- Shot Lubrication - gravity feed lubricator for spindle
- Head Swivels 360° With Positive Locating Dowels
- Head Tilts 90° right and left and 45° forward or back

Enco



Package Model 890-9190 with Enco 150 lbs. Torque Power Feed Table and 2-axis Digital Readout System.

\$7348.95

Type	Variable speed motor
RPM range	60-4200
Longitudinal Travel	35"
T-slots (No. Size)	(3) 5/8"
Saddle - Cross Travel	13.5"
Kneed Travel	16"
Spindle/Quill Travel	5"
Spindle Taper	R8
Spindle Diameter	3.375"
Spindle (Feeds) Inch/rev	(3) 0.0015", 0.003", 0.006"
Spindle to Table - Min/Max	0"-18"
Spindle to Column - Min/Max	5.5"-20"
Head Swivel, with Locks, RH/LH	90°/90°
Head Tilt - Forward and Back	45°/45°
Ram Turret Swivel	360°
Ram Travel	14.5"
Motor and Electrics	2 HP, 220V, 3 PH
Machine Dimensions	85" x 71" x 74"
Floor Space Requirements - Max	102" W x 90" D
Approx. Weight	2700 lbs.

Enco VERTICAL MILL

Design and performance features:

- R8 Spindle Taper
- 1-shot lubrication to table & saddle
- Gravity lubricator for spindle
- 10 speed step pulley drive 100 to 3500 RPM
- Turret swivels 360°
- Head tilts 90° right & left

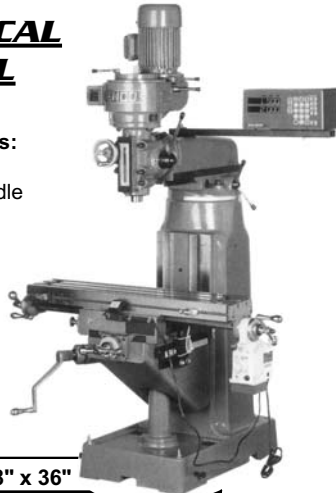

Model #100-1525
\$3798.95

Table size	8" x 36"
Speeds (RPM)	(10) 100-3500
Longitudinal Travel	23.5"
T-Slots-(No.) & Size	(3) 5/8"
Saddle - cross travel	9.45"
Knee Travel	13.75"
Spindle/Quill Travel	5.430"
Spindle Taper	R8
Spindle Diameter	3.375"
Spindle to table - Min/Max	0" / 13.75"
Spindle to column Min/Max	5 3/8" - 15 1/8"
Head swivel, w/Locks RHLH	90°L/90°R
Ram Turret Swivel	360°
Ram Travel	9.84"
Motor and electrics	1 1/2 HP, 220V, 3 PH
Machine Dimensions	76" x 48" x 44"
Floor Space Required	94"W x 60"D
Approx Wt.	1,665 lbs

Enco EXCLUSIVE R-8 MILLING & DRILLING MACHINE

#105-1117 - 16 3/8", 2 HP, 220V, 3 PH
\$990.39



Table size	8 1/4" x 28 1/2"	
Speeds (RPM)	120, 190, 230, 285, 370, 440, 770, 1040, 1220, 1450, 1800, 2500	
Capacity:	Drilling (Steel)	1 1/4"
	Drilling (Cast Iron)	1 1/2"
	End Mill	3/4"
	Face Mill	3"
Longitudinal Travel	18 1/8"	
Table Travel(Cross)	6 1/4"	
T-Slots-(No.) & Size	(4) 1/2"	
Spindle/Quill Travel	5.00"	
Spindle Taper	R8	
Spindle Diameter	3"	
Spindle to table - Max	18"	
Spindle to column Max	5 3/4"	
Motor and electrics	2 HP, 110/220V 1PH	
Machine Dimensions	43 1/2" x 32 x 43 1/2"	
Floor Space Required	54"W x 50"D	
Approx. Wt.	645 lbs.	

Enco

59 PIECE STANDARD TOOLING PACKAGE

Package Model #209-9020

Includes:

- 6 Pc. R8 Collet Set
- 6" Vise with Swivel Base
- 52 Piece Clamping Kit
 - 24 Studs, 4 of each 1/2-13, 4", 5", 6", 7", 8" long
 - 4 Coupling nuts
 - 6 Forged steel step clamps, 2 each based on stud sets
 - 6 T-nuts
 - 6 Flanged nuts
 - 6 Steel step blocks, 1" wide



Model #209-9020
\$241.18

Enco DELUXE 52 PC CLAMPING KIT

For Machines such as Enco, Turn-Pro and Bridgeport

Includes:

- 24 Studs, 4 of each 1/2" dia 3", 5", 6", 7", 8" long
- 4 Coupling nuts
- 6 Forged steel step clamps, 2 each based on stud sets
- 6 T-nuts
- 6 Flanged nuts
- 6 Steel step blocks, 1" wide
- Comes in fitted steel rack that hangs on machines, or sits on the table



Model	Table Slot	Stud Size	Your Cost	Weight
400-2376	3/8"	5/16"-18	\$83.18	16 lbs.
400-2438	7/16"	3/8"-16	\$101.82	18 lbs.
400-2501	1/2"	3/8"-16	\$71.35	18 lbs.
400-2562	9/16"	1/2"-13	\$79.89	23 lbs.
505-6544	5/8"	1/2"-13	\$76.02	27 lbs.
400-2688	11/16"	5/8"-11	\$132.35	29 lbs.
400-2751	3/4"	5/8"-11	\$132.68	29 lbs.

TURN-PRO

3-HP VARIABLE SPEED VERTICAL MILLING MACHINE

with R8 Spindle and 9"x49" Table

The spindle is supported by Super Precision Class 7 Angular Contact Bearings which have been accurately measured, selected and preloaded then assembled in a temperature controlled environment to ensure accuracy and rigidity throughout the full RPM range. Head is extremely quiet with dynamically balanced pulleys and chrome plated motor shaft for smooth speed changes free of noise and vibration. The double nut arrangement utilized on the table and saddle substantially reduces backlash and can be adjusted quickly.

Solid quill feed utilizes a one-piece pinion gear and shaft as well as a one-piece worm and wormshaft which provides strength, rigidity and less maintenance.

Made in USA power feed and accessories available. Please call Customer Service for details.

Model 307-3678
Vertical Milling Machine
Low Price
\$6897.95

Model 890-9988
\$7897.95

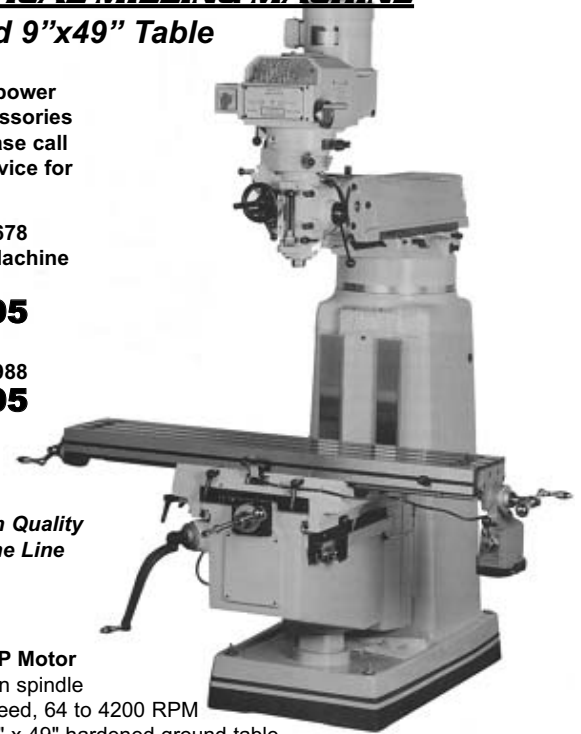

Production Quality
Top of the Line

Powerful 3 HP Motor

- R8 precision spindle
- Variable speed, 64 to 4200 RPM
- Precision 9" x 49" hardened ground table
- Powerful 3 HP Motor
- Dynamically balanced head for quiet trouble-free operation
- Hand scraped turret column ways
- Upper and lower surface of saddle laminated with Turcite-B for a smooth accurate and wear resistant surface
- Certified Meehanite casting stress relieved to provide a rigid machine structure
- Double wall column
- US patented ram locking system
- Precision hardened and ground ways
- Built-in coolant tank in base
- Backlash adjustment
- Solid quill feed
- 1-shot lubrication; gravity feed lubricator for spindle
- All moveable surfaces are lockable
- Way covers for knee and crossfeed
- Double lock devices on knee, saddle, and table provide superior holding power and eliminate possibility of lateral movement

Model No.	307-3678	890-9988
Table Size	9x49	10x54
Variable Speed	600-4200 70-500	600-4200 70-500
Longitudinal Travel	35" w/o Pwr Feed 31" w / Pwr Feed	39" w/o Pwr Feed 34" w / Pwr Feed
T-Slots	(3) 5/8" x 1-1/4"	(3) 5/8" x 1-1/4"
Sadle-Cross Travel	12"	16.5"
Knee Travel	16.5"	17.750"
Spindle/Quill Travel	5"	5"
Spindle Taper	R8	R8
Spindle Diameter	3.375"	3.375"
Spindle Feeds in/rev	(3) .0015, .003, .006	(3) .0015, .003, .006
Spindle to Table	0-18 15/16"	0-20"
Spindle to Column	5"-20"	7"-26"
Head Swivel, w/Locks	90°/90°	90°/90°
Head Tilt - Forward & Back	45°/45°	45°/45°
Ram Turret Swivel	360°	360°
Ram Travel	12"	18"
Motor & Elec.	3 HP 220/440 3 ph	3 HP 220/440 3 ph
Machine Dimensions	85"x59"x55"	88"x72"x66"
Machine Base Dimensions	37 1/2" x 24"	43"x24"
Floor Space Req'd	140"w x 70"d	150"w x 94"d

BENCH LATHES

JET BELT DRIVE BENCH LATHE

Design and Performance Features:

- Spindle is supported by precision tapered roller bearings
- Hardened and ground bedways
- Power longitudinal feed allows threading
- Standard 1 1/2" x 8 TPI spindle nose allows for many aftermarket accessories
- A reversing switch is included for added versatility
- Backlash adjustments are provided throughout the carriage
- The tailstock can be adjusted for taper cut
- Quick change gear box provides wide range of inch and metric threads

Standard Equipment

- 7" 4-jaw and 4" 3-jaw chuck with threaded back plate
- Face plate
- 4-way tool post
- Single tool post
- Steady and follow rest
- Metric change gears
- Threading dial
- Toolbox and tool

Optional Equipment

- Cabinet Stand (321374)
- Live Center (465302)



Shown w/ optional stand

Model	#BD-920N
Swing Over Bed	8 3/4"
Swing Over Cross Slide	5 1/4"
Distance Between Centers	20"
Hole Through Spindle	25/32"
Spindle Mount	1 1/2" x 8 TPI
Spindle Taper	MT-3
Number of Spindle Speeds	6
Range of Spindle Speeds (RPM)	130-2000
Number of Longitudinal Feeds	27
Range of Longitudinal Feeds (in/rev)	0.005-0.011
Number of Inch Threads	27
Range of Inch Threads	8-56 TPI
Number of Metric Threads	11
Range of Metric Threads (mm)	5-3
Max Tool Size (in)	1/2" x 1/2"
Compound Slide Travel (in)	1 7/8"
Cross Slide Travel (in)	5"
Carriage Travel (in)	16"
Tailstock Spindle Travel (in)	1 9/16"
Taper in Tailstock Spindle	MT-2
Steady Rest Capacity	1 7/8"
Follow Rest Capacity	1 7/8"
Width of Bed (in)	4 7/8"
Overall Dimensions With Stand	37 1/2"L x 20"W x 45"H
Main Motor	3/4 HP, 1 PH, 115V only
Shipping Weight (approx. lbs.)	304

Lathe Only
\$1295.00

Lathe w/ Cabinet
\$1599.00

Enco

12" X 36" BENCH LATHE WITH BACK GEAR 12 Speeds 50-1200 RPM with Reversing Switch

Design and Performance Features

- Powerful 1.5 HP Motor 1 Phase, 220 Volt
- 12 Speeds 50 to 1200 RPM
- Hardened and ground bed
- 2 1/4" - 8 threaded spindle
- Easy speed controls
- Reversing switch
- 1 13/32" spindle bore diameter
- Splash lubrication in head stock

Each Lathe Comes with FREE BONUS PACKAGE

- 6" 3-jaw chuck mounted on your lathe
- 7" 4-jaw chuck
- 1 1/16" capacity 4-way tool post
- 8" Back plate
- 10 " Face plate
- Steady Rest
- 2-MT Dead center
- Chip Pan
- Metric Change Gears
- Follow Rest
- Toolbox



Specifications

Table work surface area	12" x 36"
Swing over bed	12"
Swing over cross slide	7"
Swing over compound	3"
Distance between centers	37"
Carriage travel	32"
Longitudinal feed range (In/Rev)	0.0047"-0.132"
Inch threads (Number) Range (50)	4-112 TPI
Metric threads (Number) Range (24)	0.5mm - 4.5mm
Cross slide travel	6 5/16"
Cross slide feed range	0.0030" - 0.0913"
Compound travel	3 1/2"
Tailstock spindle travel	3 5/8"
Tailstock taper	2-MT
Spindle nose mounting	2 1/4" x 8 TPI
Spindle bore diameter	1 13/32"
Spindle taper	5 MT
Spindle taper with sleeve	3 MT
Spindle speeds (Number) Range	(12) 50 -1200
Motor & Electrics	1-1/2HP, 220V, 1PH
Machine Dimensions	23"H x 32"W x 62"L
Floor space required - Max	36" D - 70" W

Model #110-2037
Bench Lathe Only
Low Price
\$2548.95
Net Wt 900 lbs.

Model #110-2038
Bench Lathe (110-2037)
w/ 2 door Cabinet Stand
(258-9040)
Low Price
\$2773.95
Net Wt 1050 lbs.

Model #110-2039
Bench Lathe (110-2037) w/ 2
Door Cabinet Stand
(258-9040) and Digital Read
Out (258-9040)
Low Price
\$3973.95
Net Wt 1090 lbs.

ENGINE LATHES

TURN-PRO

HEAVY DUTY 13" X 40" GAP BED ENGINE LATHE Combines High Speed and Precision

Design and Performance Features

- Powerful 3 HP motor, 3 PH, 220V
- Headstock with tapered roller bearings
- Meehanite casting
- 1 9/16" spindle bore diameter
- Induction hardened bed
- Splash lubrication in headstock
- Full length splash guard
- Thread chasing dial
- 2 stage leadscrew
- Chip tray
- Tang driven tailstock
- Non-asbestos foot brake
- Coolant system
- Change gears

Standard Equipment

- 8" 3-jaw chuck
- 8" 4-jaw chuck
- 12" faceplate
- Steady rest and follow rest
- 3-MT dead center
- 4 way toolpost
- 1 3/8" capacity
- Chip Pan
- Splash guard
- Metric change gears
- Threading dial
- Coolant system
- Foot brake
- Toolbox with tools



Model #111-3115
Lathe
Low Price
\$7197.95

Specifications

Table Work Surface Area	13" x 40"
Swing Over Bed	13"
Swing Over Gap	21"
Length of Gap	9 1/6"
Swing Over Cross Slide	8"
Swing Over Compound	3 1/2"
Distance Between Centers	40"
Carriage Travel	46"
Longitudinal Feed Range (Inch/Rev)	0.002" - 0.04"
Inch Threads (Number) Range	(40) 112-4 TPI
Metric Threads (Number) Range	(22) .25mm - 6mm
Cross Slide Travel	8"
Cross Slide Feed Range	0.002" - 0.04"
Compound Travel	3 3/4"
Tailstock Spindle	4"
Tailstock Taper	3 MT
Spindle Nose Mounting	D1-4
Spindle Bore Dia.	1 9/16"
Spindle Taper	5 MT
Spindle Speeds (Number) Range	(8), 65-2000
Motor and Electrics	3 HP, 220V, 3ph
Machine Dimensions	72"L x 32"W x 48"H
Floor Space Required	80"L x 36"W x 52"H

Enco

13" X 40" & 14" X 40" GEARED HEAD GAP BED ENGINES LATHES

Design and Performance Features

- 16 speeds 45-1800 RPM
- Quick speed changes
- Hardened and ground bedways
- Footbrake
- Spindle with tapered roller bearing
- Totally enclosed gearbox
- Powerful 3 HP Motor, 220V, 3 PH
- Splash lubrication in headstock
- Jog button for easy gear engagement and spindle inching
- Full length splash guard
- Coolant system

Standard Equipment

13" x 40"

- 6" 3-Jaw Chuck
- 8" 4-Jaw Chuck
- 12" Faceplate
- 5 1/8" Backplate
- Steady rest
- Follow rest
- 3-MT Dead Center
- 3-MT Live Center
- 4 way Tool Post 1 1/8" Cap
- Chip Pan
- Splash Guard
- Metric Change Gears
- Threading Dial
- Coolant System
- Foot Brake
- Toolbox with tools

14" x 40"

- 8" 3-Jaw Chuck
- 10" 4-Jaw Chuck
- 12 3/4" Faceplate
- 6 1/4" Backplate
- Steady rest
- Follow rest
- 3-MT Dead Center
- 3-MT Live Center
- 4 way Tool Post 1 1/4" Cap
- Chip Pan
- Splash Guard
- Metric Change Gears
- Threading Dial
- Coolant System
- Foot Brake
- Toolbox with tools



**Lower Prices
While they last**

Specifications

Table Work Surface Area	13" x 40"	14" x 40"
-Swing Over Bed	13"	14"
-Swing Over Gap	19"	19.92"
-Swing Over Cross Slide	7 5/8"	6.66"
-Distance Between Centers	40"	40"
Tailstock Taper	3 MT	3 MT
Spindle Bore Dia.	1 1/2"	1 1/2"
Spindle Taper	5 MT	5 MT

13" Model
#308-0233
Lathe
~~\$5269.75~~
NOW \$4997.95
Wt. 1808 lbs.

13" Package Model
#308-0234
Lathe with 2-Axis DRO
(240-7746) INSTALLED
FREE
~~\$6468.75~~
NOW \$6197.95
Wt 1840 lbs.

14" Model
#308-0232
Lathe
~~\$5748.95~~
NOW \$5497.95
Wt 1940 lbs.

14" Package Model
#308-0235
Lathe with 2-Axis DRO
(#240-7746)
INSTALLED FREE
~~\$6947.95~~
NOW \$6697.95
Wt 1970 lbs.

IRVAN-SMITH, INC.

1027 Central Drive
 Concord, North Carolina 28027
Phone 704-788-2554 800-221-7223
FAX 704-784-4120
E-Mail: info@irvansmith.com
Website: http://www.IrvanSmith.com



*We haul our most precious cargo in
 the Irvan-Smith, Inc pit cart.
 (Scott and Lauren Smith)*

Since 1982, Irvan Smith, Inc. has provided customers with excellent service and low prices on quality tools and equipment. The Irvan-Smith, Inc. family includes: Vic & Jo Irvan; Kevin & Tracy Smith; Brian Currin, fabricating & welding specialist (12 years); Darryl Church, shipping & receiving specialist (7 years); Chris Music, Sales Manager (6 years); and Chad Dotseth, fabricating specialist (5 years). We all do our best each day to provide our customers with excellent service and low prices on quality tools and equipment. We want to thank you for your loyalty and your friendship. We are proud to say that we have been blessed with the best customers in the world!

Remember that our list prices are based on racers' net to give everyone the best price possible. If you are trying to outfit a complete shop, call us about a package price. If you don't see a model or part that you want, give us a call and we'll do our best to get it for you while trying to save you some money.

Thank you for 26 successful years. We hope to hear from you or see you in person. If you can't visit us in person, visit our website at www.IrvanSmith.com. You can also see our products on *Dream Car Garage* and *American Chopper!*

Effective November 2007-November 2008

- Prices in this catalog are subject to change without notice -

ORDER BY PHONE: 1-800-221-7223 - Hours 8:00 a.m. to 5:00 p.m. Monday thru Friday. You are assured of receiving prompt, courteous service from our sales staff. **Visit <http://www.IrvanSmith.com> and order 24 hours a day!**

NO MINIMUM ORDER REQUIRED!

SHIPPING: Most items can be shipped UPS. All items shipped by truck must be prepaid and will be shipped FOB point of origin.

COD ORDERS: (Certified Check or Money Order). There is a COD fee charged by UPS plus Freight charges.

PREPAID ORDERS: You may use either Visa, Mastercard or American Express. Personal or Company checks may be held for 7 days, therefore a slight delay in shipping may result.

WAIVER AND WARRANTY: Irvan-Smith, Inc. will repair or replace any product manufactured by Irvan-Smith, Inc. found upon our inspection to be defective in workmanship or material within 90 days from the date of purchase. Irvan-Smith, Inc. will not be liable for any loss, damage, or injury arising from the use of any product we sell. **RACING IS A DANGEROUS ACTIVITY!** The user shall determine the suitability and safety of the product for its intended use, and the user assumes all responsibility and risk in connection therein.

RETURNS: No returns accepted without prior approval and RA number. Item must be in new/unused condition. A restocking fee will be charged. No returns accepted on special order items.

REFUNDS: Absolutely no refunds after 30 days.

FREIGHT CLAIMS: Any claims for damage or loss must be filed with carrier by purchaser.

IRVAN-SMITH APPAREL



T-Shirts **\$10.00 ea.**



Ball Cap **\$10.00 ea.**



**KETT KIT NO.
 300 CORDLESS
 18 GA. POWER
 SHEAR KIT**
 #KB-301-K2
 List \$495.00
**Sale Price
 \$300.00**
 While they last!

A

- Abrasives42
- Air Compressors42
- Air Gauge28-29
- Air Tank28
- Air Riveter3
- Aluminum Wheels22
- Aluminum Snips14
- Apparel50
- Aurora Rod Ends**6

B

- Back-up washers2
- Band Saws37-40, 44
- Bead Rollers7
- Bead Mandrels7
- Bell Housing Indicator20
- Belts, Abrasive42
- Bench English Wheel12
- Benders8-9
- Beverly Shears11
- Blades, Band Saw42
- BLAST-IT-ALL**43
- BlueBird Engine Lift**25
- Books14
- Braided Hose Cutter21
- Brake Fluid20
- Brake Kit, Pit Wagon23
- Brakes30-33
- Brunnhoezl Race Jack**25
- Bump Steer Gauge25
- Burr-King**41

C

- Cam Fasteners4
- Canopies27
- Car Cover29
- Carts23-24
- Caster/Camber Gauge29
- Cleaner-Degreaser21
- Clamping Kit47
- Cleco Tool**4
- Clecos**4
- Clothing50
- Cold Saw37
- Collet Set47
- Conquest**40
- CoolDraft27
- Cooler27
- Corner Notcher15
- Countersink Set3
- Countersink Tool3
- Crimper10
- Cutter Dies10

D

- Deburring Tool3
- Dial Caliper20
- Dial Indicators20
- Discs, Abrasive42
- Dollies13
- Drill Bits3
- Drill Fixture4, 20
- Drill Presses44-45
- Dump Can Stands25
- DVD, Instructional13

E

- Eckold Shrinker & Stretcher**10
- Ercolina Super Bender**9
- Edger, "E-Z"7
- Ellis**38-39, 41, 45
- Enco**11, 15, 32, 36-37, 40, 45-49
- Engine Lift25
- English Wheel12
- English Wheel, DVD13

F

- Fabricating Books14
- Fasteners2-5
- Forming Tools12-13
- Fournier**12-13
- Front Wheel Kit24
- Fuel Transfer Pump25

G

- Gas Cart24
- Gas Restraint24
- Glass Bead Cabinet43
- Glass Beads43
- Gloves43
- Greenlee-**16
- Grinders40-41, 44
- Grob**40
- Grommets, Cam Fastener4
- Gussets11

H

- Hand Notcher15
- Hand Seamer14
- Hand Shrinker10
- Handheld English Wheel12
- Handle Grips22
- Hardness Tester21
- Hats50
- Heaters20
- Height Gauges25
- Hem Roll7
- Hole Flare16
- Hole Punches16, 18-19
- Hood Pin Hardware21

I

- Impact Gun29
- Indicators20
- Ingersoll-Rand Air Compressors**42
- Iron Worker19

J

- Jack25
- Jack Bolt Tap & Die6
- Jam Nuts6
- Jet**36, 41, 45, 48

K

- Kett Power Shears**14, 50
- Klein Unibits**16
- Klenk Snips14
- KMT**37
- Knock-Out Punches16

L

- Latches22
- Lathe48-49
- Level21
- Lista Cabinets**17
- Load Track26
- Longacre**28-29

M

- M&R**26
- Magnabend33
- Magnetic Heater20
- Mandrel Rack7
- Mandrels - Bead Roller7
- Mandrels - Tubing Bender8-9
- Markers, Tire21
- McReynolds, Larry, Book14
- Metal Shaping Tools12-13
- Metal Ace**12
- Milling Machines46-47

N

- National**32, 34
- Nibbler Tools15
- Notchers10, 15
- Nutsert Kit3

P

- Panel Beater Bags13
- Panel Fasteners5
- Phase II**20-21
- PipeMaster11
- Pit Wagons & Carts22-24
- Planishing Hammer12
- Plastic Mallet13
- Plate Brake32
- Plate Shear11
- Pliers, Safety Wire20
- POP Air Riveter**3
- Pop-Up Tents27
- Post Dollies13
- Proformer Brakes**30-31
- ProLine**12
- Punch & Flange Tool15
- Punch & Flare16
- Punches14-16, 18, 19

Q

- Quarter-Turn Fasteners4-5
- Quickshaper12

R

- Race Jacks25
- Radius Brake31
- RATCO Planishing Hammer**12
- Ride Height Gauge25
- Rivet Drill Bits3
- Rivet Guns3
- Rivet Nutter3
- Rivets2-3
- Rod Ends6
- Roll-In Saw**44
- Roper Whitney**15, 18, 33, 35-36
- Rotex Punch**19

S

- Safety Wire20
- Safety Wire Pliers20
- Sand Blaster43
- Sander/Grinders40-41, 44
- Sanding Discs42
- Saw Blades37-39, 42
- Saws, Band Saws37-40, 44
- Saws, Cold37
- Scales28
- SD-20**21
- Shears14, 34-35, 50
- Shoe Sets, Tubing Bender8-9
- Shrinker/Stretcher10
- Shrinker/Stretcher Jaws10
- Side Grip Fasteners4
- Slip Roller36
- SmartLevel21
- Snips14
- Socket & Plunger22
- Speedway Directory14
- Spindle Kit22
- Spring Plate5
- Springs5
- Steering Shaft Rod End6
- Step Drill Bits16

T

- T-Dollies13
- Taps, Rod Ends6
- Tents27
- Thickness Gauge21
- Tie Down Straps26
- Tin Snips14
- Tire Bead Breakers21
- Tire Carts & Racks24
- Tire Gauge28-29
- Tire Pyrometer29
- Tires22, 26
- Toolboxes17, 23
- Trace-A-Punch**15
- Trailer Accessories26
- Transfer Punches14
- Trigger Latches22
- T-Shirts50
- TubeShark9
- Tubing Bender8-9
- Tubing Bender Shoe Sets8-9
- Tubing Notcher9-10
- Tubing Notcher Cutter Dies10

U

- Ultrasonic Testers21
- Uni-Bits16
- Unihydro**19

V

- Vise47

W

- Wagons, Pit & Toolbox23
- Wheel Covers22
- Wheels22, 26
- Wilton**44
- Wireless Scales28
- Wing Nut Fasteners4-5
- Wood Slappers13

X

- XX Punch18

**IF YOU CAN'T
FIND WHAT
YOU'RE
LOOKING
FOR, GIVE US
A CALL AND
WE WILL TRY
TO GET IT
AND SAVE
YOU A LITTLE
MONEY**



NEW ITEMS FOR 2008



**TubeShark
SharkPool
Tubing Bender**
Pg. 9



**Foot Operated
Shrinker -
Stretcher Stand**
Pg. 10



**ProLine
Planishing
Hammer**
Pg. 12



**ProLine Handheld
Planishing
Hammer**
Pg. 12



**SmartTool
Angle Finder**
Pg. 21



**No Tip
Tire Cart**
Pg. 24



**Wireless
Scales**
Pg. 28



**Rechargeable
Pit Impact Gun**
Pg. 29



**Conquest Combo
Sander/Grinder**
Pg. 40



**Roll In Saw
Bandsaw**
Pg. 44



**Handheld
English Wheel**
Pg. 12



**55 Gal. Drum
Cart**
Pg. 24



704-788-2554
800-221-RACE (7223)

Shop Online
24/7/365

FAX 704-784-4120

email: info@irvansmith.com

Website: <http://www.IrvanSmith.com>